

## -30V Dua P-Channel Enhancement Mode MOSFET

### 1. Product Information

#### 1.1 Features

- ◇ Surface-mounted package
- ◇ Advanced TRENCH cell design

#### 1.2 Applications

- ◇ LED Display appliances
- ◇ High power inverter system
- ◇ LCDM appliances

#### 1.3 Quick reference

- ◇  $BV \cong -30\text{ V}$
- ◇  $P_{\text{tot}} \cong 2\text{ W}$
- ◇  $I_D \cong -6.3\text{ A}$
- ◇  $R_{\text{DS(ON)}} \cong 55\text{ m}\Omega @ V_{\text{GS}} = -10\text{ V}$
- ◇  $R_{\text{DS(ON)}} \cong 65\text{ m}\Omega @ V_{\text{GS}} = -4.5\text{ V}$

### 2. Pin Description

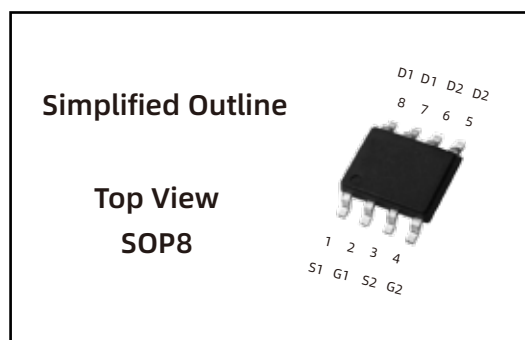
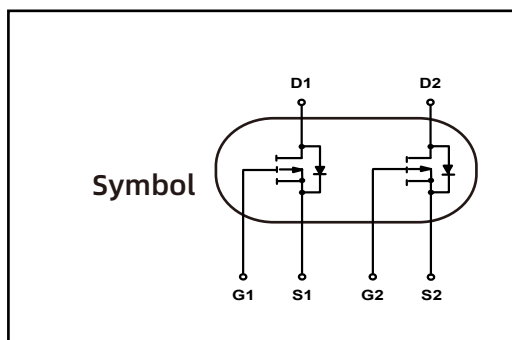

### 3. Marking Information

Product Name	Marking
LN420P030SD	LN420P030SD CYWWZZ XXXXXX

## 4. Limiting Values

Symbol	Parameter	Conditions	Min	Max	Unit
$V_{DS}$	Drain-Source Voltage	$T_A = 25\text{ }^\circ\text{C}$	- 30	-	V
$V_{GS}$	Gate-Source Voltage	$T_A = 25\text{ }^\circ\text{C}$	-	$\pm 20$	V
$I_D^*$	Drain Current	$T_A = 25\text{ }^\circ\text{C}, V_{GS} = -10\text{ V}$	-	- 6.3	A
		$T_A = 100\text{ }^\circ\text{C}, V_{GS} = -10\text{ V}$	-	- 4	A
$I_{DM}^{*,**}$	Pulsed Drain Current	$T_A = 25\text{ }^\circ\text{C}, V_{GS} = -10\text{ V}$	-	- 25	A
$P_{tot}$	Total Power Dissipation	$T_A = 25\text{ }^\circ\text{C}$	-	2	W
$T_{stg}$	Storage Temperature		- 55	150	$^\circ\text{C}$
$T_j$	Junction Temperature		- 55	150	$^\circ\text{C}$
$I_s$	Diode Forward Current	$T_A = 25\text{ }^\circ\text{C}$	-	- 6.3	A
$R_{\theta JA}^*$	Thermal Resistance- Junction to Ambient		-	56	$^\circ\text{C}/\text{W}$

Notes :

\* Surface Mounted on 1 in<sup>2</sup> pad area, t ≤ 10 sec

\*\* Pulse width ≤ 300 μs, duty cycle ≤ 2 %

## 5. Ordering Code

Product Name	Package	Reel Size	Tape width	Quantity	Note
LN420P030SD	SOP8	Ø330mm	12mm	3000	

Note: COMTECH defines " Green " as lead-free ( RoHS compliant ) and halogen free ( Br or Cl does not exceed 900 ppm by weight in homogeneous material and total of Br and Cl does not exceed 1500 ppm by weight; Follow IEC 61249-2-21 and IPC / JEDEC J-STD-020C )

## 6. Electrical Characteristics ( $T_A=25^\circ$ Unless Otherwise Noted )

Symbol	Parameter	Conditions	Min	Typ	Max	Unit
<b>Static Characteristics</b>						
$BV_{DSS}$	Drain-Source Breakdown Voltage	$V_{GS} = 0\text{ V}, I_{DS} = -250\ \mu\text{A}$	- 30	-	-	V
$V_{GS(th)}$	Gate Threshold Voltage	$V_{DS} = V_{GS}, I_{DS} = -250\ \mu\text{A}$	- 1.0	-	- 2.0	V
$I_{DSS}$	Drain Leakage Current	$V_{DS} = -24\text{ V}, V_{GS} = 0\text{ V}$	-	-	- 1.0	$\mu\text{A}$
$I_{GSS}$	Gate Leakage Current	$V_{DS} = 0\text{ V}, V_{GS} = \pm 20\text{ V}$	-	-	$\pm 100$	nA
$R_{DS(on)}^a$	On-State Resistance	$V_{GS} = -10\text{ V}, I_{DS} = -6\text{ A}$	-	45	55	m $\Omega$
		$V_{GS} = -4.5\text{ V}, I_{DS} = -3\text{ A}$	-	55	65	
<b>Diode Characteristics</b>						
$V_{SD}^a$	Diode Forward Voltage	$I_{SD} = -6\text{ A}, V_{GS} = 0\text{ V}$	-	-	- 1.3	V
$t_{rr}$	Reverse Recovery Time	$I_{SD} = -6\text{ A}$	-	38	-	nS
$Q_{rr}$	Reverse Recovery Charge	$dI_{SD}/dt = 100\text{ A}/\mu\text{s}$	-	17	-	nC
<b>Dynamic Characteristics<sup>b</sup></b>						
$C_{ISS}$	Input Capacitance	$V_{GS} = 0\text{ V}, V_{DS} = -15\text{ V}$ Frequency = 1 MHz	-	750	-	pF
$C_{OSS}$	Output Capacitance		-	115	-	
$C_{rSS}$	Reverse Transfer Capacitance		-	75	-	
$t_d(on)$	Turn-on Delay Time	$V_{DS} = -15\text{ V}, V_{GEN} = -10\text{ V},$ $R_G = 4.5\ \Omega, R_L = 2.5\ \Omega,$ $I_{DS} = -6\text{ A}$	-	7	-	nS
$t_r$	Turn-on Rise Time		-	3	-	
$t_d(off)$	Turn-off Delay Time		-	30	-	
$t_f$	Turn-off Fall Time		-	12	-	
<b>Gate Charge Characteristics<sup>b</sup></b>						
$Q_g$	Total Gate Charge	$V_{DS} = -15\text{ V}, V_{GS} = -10\text{ V},$ $I_{DS} = -6\text{ A}$	-	9.5	-	nC
$Q_{gs}$	Gate-Source Charge		-	2	-	
$Q_{gd}$	Gate-Drain Charge		-	3	-	

Notes :

a : Pulse test ; pulse width  $\leq 300\ \mu\text{s}$ , duty cycle  $\leq 2\%$

b : Guaranteed by design, not subject to production testing

## 7. Typical Characteristics

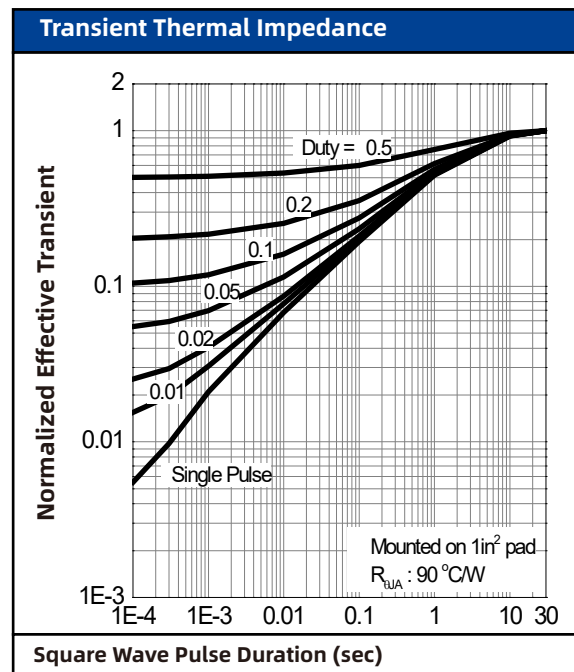
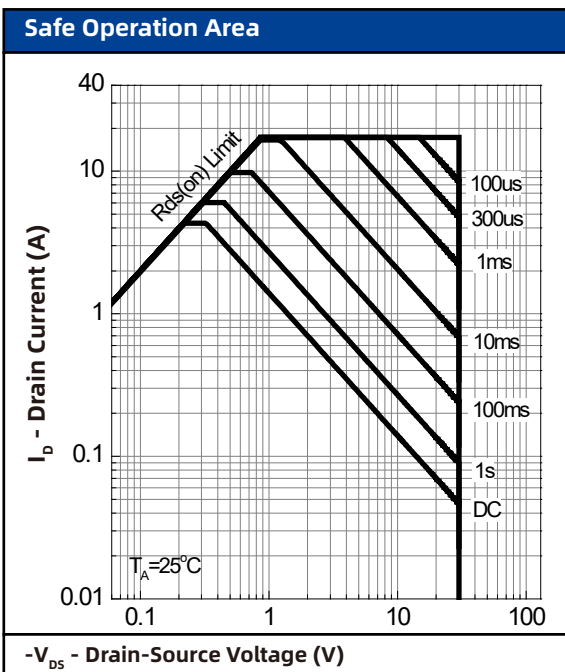
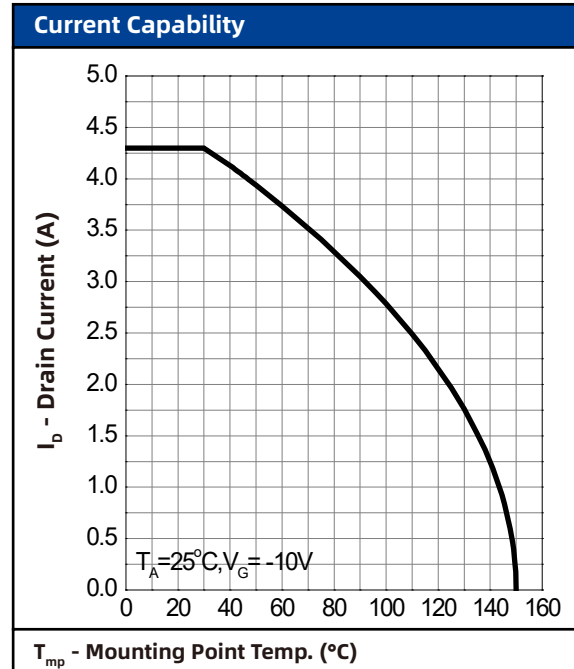
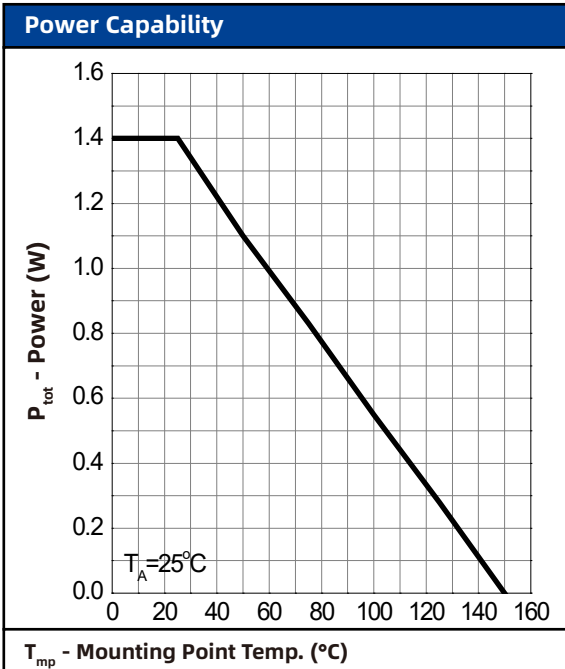

## 7. Typical Characteristics (cont.)

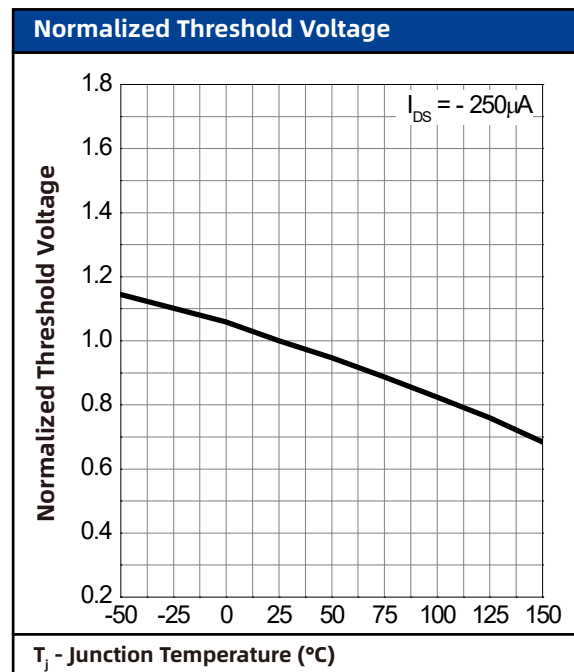
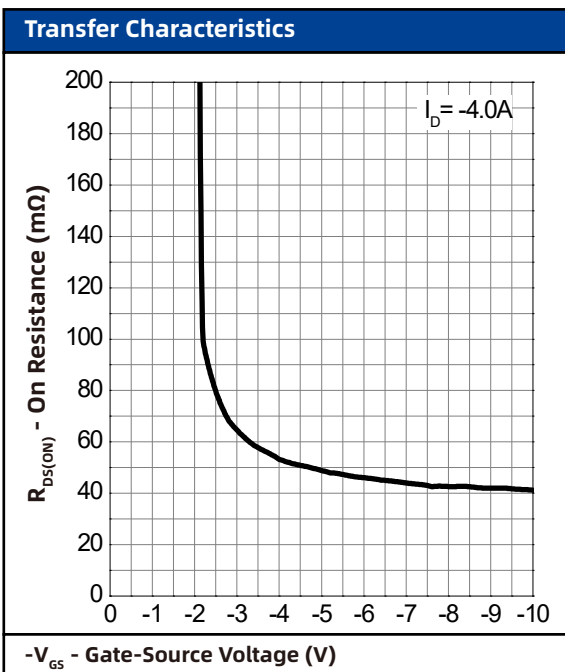
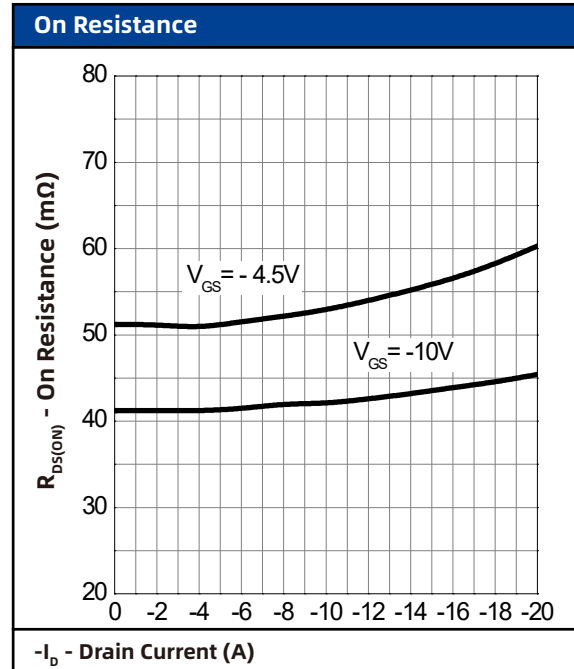
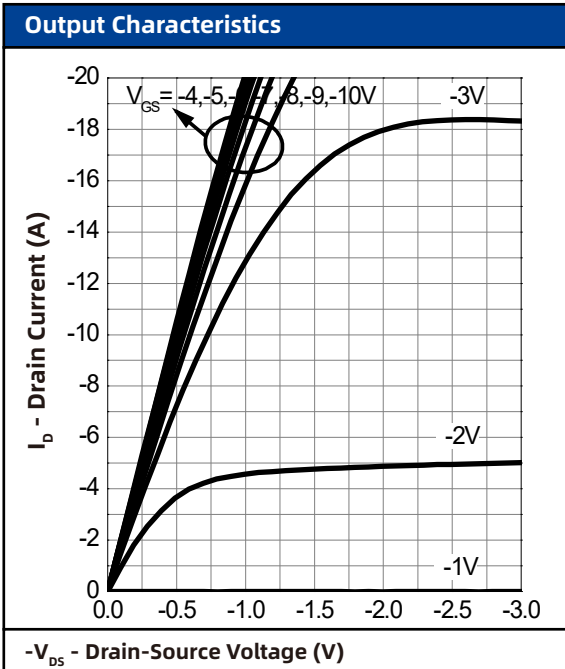

## 7. Typical Characteristics (cont.)

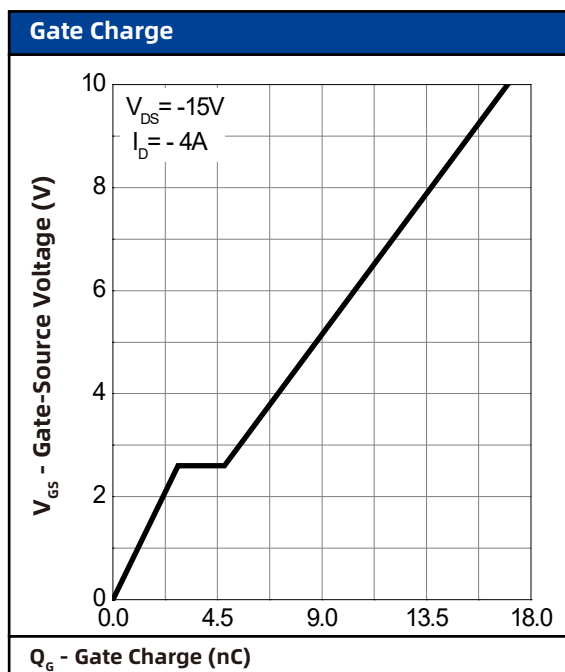
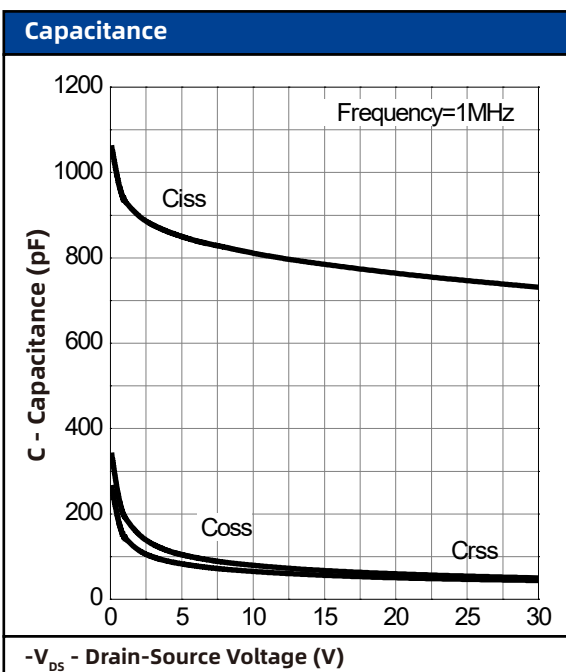
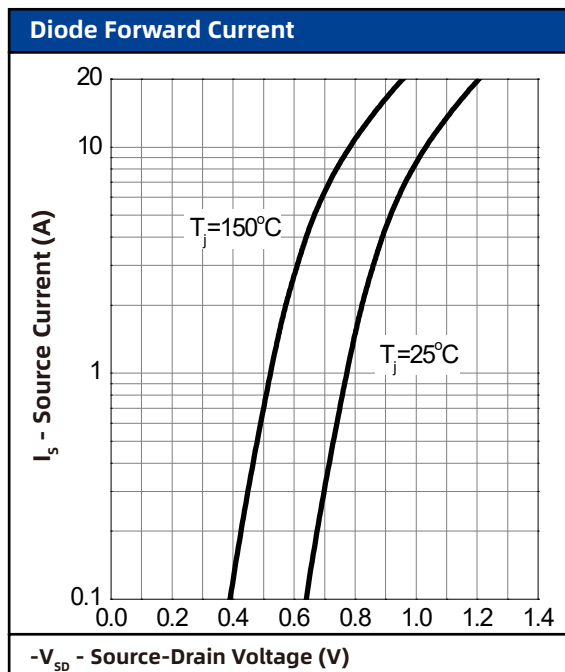
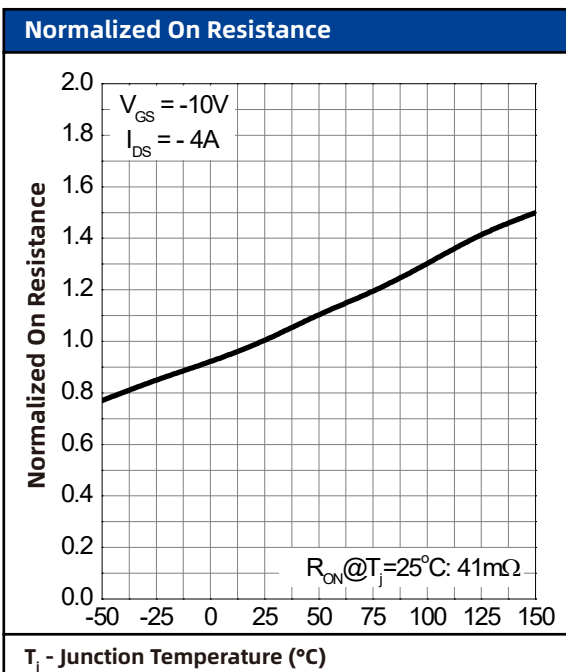

## 8. Package Dimensions

### SOP8 Package

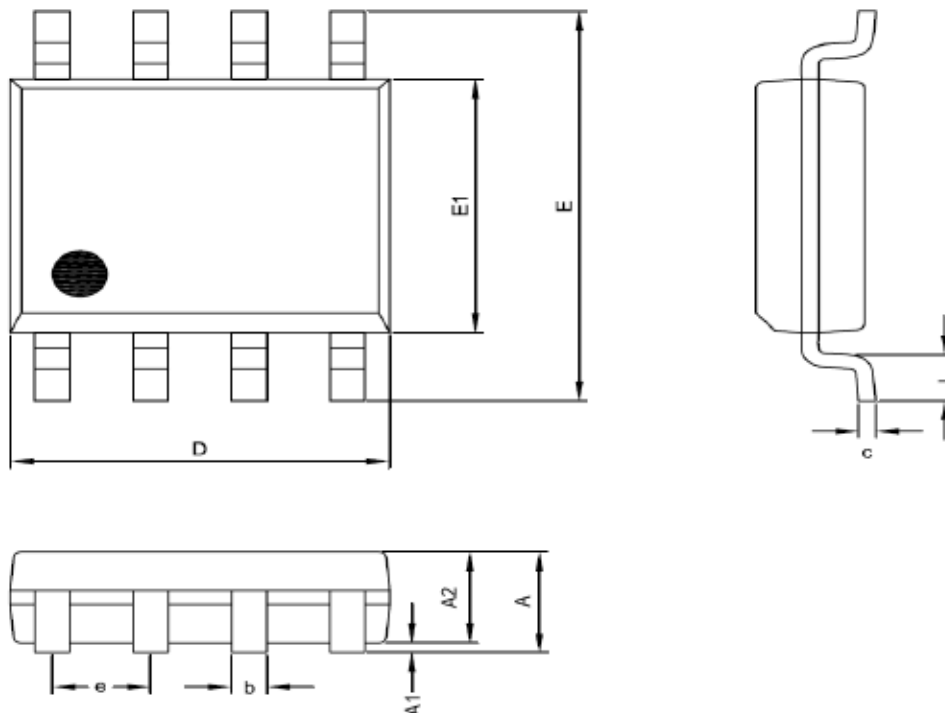

Symbol	Dimensions In Millimeters	
	Min.	Max.
A	1.35	1.75
A1	0.00	0.25
A2	1.15	1.50
D	4.80	5.00
E	5.80	6.20
E1	3.80	4.00
c	0.19	0.27
b	0.33	0.53
e	1.27 BSC	
L	0.40	1.27

Notes :

a : Jedec outline:MS-012AA

b : Dimensions " D " does not include mold flash, protrusions and gate burrs shall not exceed .15 mm (.006 in) per side.

c : Dimensions " E1 " does not include inter-lead flash, or protrusions. Inter-lead flash and protrusions shall not exceed .25 mm (.010 in) per side.