

120V N-Channel Enhancement Mode MOSFET

1. Product Information

1.1 Features

- ◇ Surface-mounted package
- ◇ Low Thermal Resistance
- ◇ Advanced SGT cell design

1.2 Applications

- ◇ Motor drivers
- ◇ DC - DC Converter

1.3 Quick reference

- ◇ $BV \cong 120\text{ V}$
- ◇ $P_{\text{tot}} \cong 71\text{ W}$
- ◇ $I_D \cong 73\text{ A}$
- ◇ $R_{\text{DS(ON)}} \cong 5.0\text{ m}\Omega @ V_{\text{GS}} = 10\text{ V}$
- ◇ $R_{\text{DS(ON)}} \cong 7.5\text{ m}\Omega @ V_{\text{GS}} = 6\text{ V}$

2. Pin Description

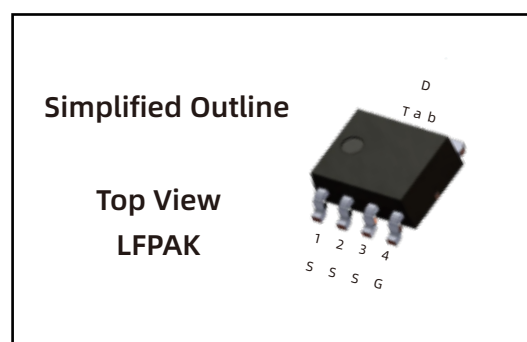
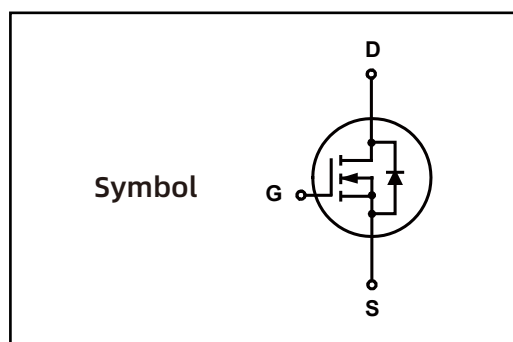

3. Marking Information

| Product Name | Marking |
|---------------|-----------------------------------|
| LN043N120LF-H | LN043N120LF-H CYWWZZ XXXXXX |

4.Limiting Values

| Symbol | Parameter | Conditions | Min | Max | Unit |
|-------------------|---|---|-----|----------|--------------------|
| V_{DS} | Drain-Source Voltage | $T_C = 25\text{ }^\circ\text{C}$ | - | 120 | V |
| V_{GS} | Gate-Source Voltage | $T_C = 25\text{ }^\circ\text{C}$ | - | ± 20 | V |
| I_D | Drain Current | $T_C = 25\text{ }^\circ\text{C}, V_{GS} = 10\text{ V}$ | - | 73 | A |
| | | $T_C = 100\text{ }^\circ\text{C}, V_{GS} = 10\text{ V}$ | - | 51 | A |
| I_{DM}^{**} | Pulsed Source Current | $T_C = 25\text{ }^\circ\text{C}, V_{GS} = 10\text{ V}$ | - | 292 | A |
| P_{tot} | Total power dissipation | $T_C = 25\text{ }^\circ\text{C}$ | - | 71 | W |
| T_{stg} | Storage Temperature | | -55 | 175 | $^\circ\text{C}$ |
| T_J | Junction Temperature | | - | 175 | $^\circ\text{C}$ |
| I_S | Diode Forward Current | $T_C = 25\text{ }^\circ\text{C}$ | - | 73 | A |
| E_{AS} | Single Pulsed Avalanche Energy | $V_{DD} = 50\text{ V}, L = 1.0\text{ mH}$ | - | 925 | mJ |
| $R_{\theta JA}^*$ | Thermal Resistance- Junction to Ambient | | - | 58 | $^\circ\text{C/W}$ |
| $R_{\theta JC}$ | Thermal Resistance- Junction to Case | | - | 2.1 | |

Notes :

- * Surface Mounted on 1 in² pad area, $t \leq 10\text{ sec}$
- ** Pulse width $\leq 300\text{ }\mu\text{s}$, duty cycle $\leq 2\%$
- *** Limited by bonding wire

5.Ordering Code

| Product Name | Package | Reel Size | Tape width | Quantity | Note |
|---------------|----------|----------------------------|------------|----------|------|
| LN043N120LF-H | LFPAK5*6 | $\varnothing 330\text{mm}$ | 12mm | 5000 | |

Note: COMTECH defines " Green " as lead-free (RoHS compliant) and halogen free (Br or Cl does not exceed 900 ppm by weight in homogeneous material and total of Br and Cl does not exceed 1500 ppm by weight; Follow IEC 61249-2-21 and IPC / JEDEC J-STD-020C)

6. Electrical Characteristics ($T_A=25^\circ$ Unless Otherwise Noted)

| Symbol | Parameter | Conditions | Min | Typ | Max | Unit |
|--|--------------------------------|---|-----|------|-----------|---------------|
| Static Characteristics | | | | | | |
| BV_{DSS} | Drain-Source Breakdown Voltage | $V_{GS} = 0\text{ V}, I_{DS} = 250\ \mu\text{A}$ | 120 | - | - | V |
| $V_{GS(th)}$ | Gate Threshold Voltage | $V_{DS} = V_{GS}, I_{DS} = 250\ \mu\text{A}$ | 2 | - | 4 | V |
| I_{DSS} | Drain Leakage Current | $V_{DS} = 96\text{ V}, V_{GS} = 0\text{ V}$ | - | - | 1 | μA |
| I_{GSS} | Gate Leakage Current | $V_{GS} = \pm 20\text{ V}, V_{DS} = 0\text{ V}$ | - | - | ± 100 | nA |
| $R_{DS(on)}^a$ | On-State Resistance | $V_{GS} = 10\text{ V}, I_{DS} = 30\text{ A}$ | - | 4.3 | 5.0 | m Ω |
| | | $V_{GS} = 6\text{ V}, I_{DS} = 20\text{ A}$ | - | 6.8 | 7.5 | |
| Diode Characteristics | | | | | | |
| V_{SD}^a | Diode Forward Voltage | $I_{SD} = 30\text{ A}, V_{GS} = 0\text{ V}$ | - | - | 1.3 | V |
| t_{rr} | Reverse Recovery Time | $I_{DS} = 30\text{ A}, V_{GS} = 0\text{ V}$ | - | 97 | - | nS |
| Q_{rr} | Reverse Recovery Charge | $di_{SD}/dt = 100\text{ A}/\mu\text{s}$ | - | 323 | - | nC |
| Dynamic Characteristics^b | | | | | | |
| C_{ISS} | Input Capacitance | $V_{GS} = 0\text{ V}, V_{DS} = 60\text{ V}$ Frequency = 1 MHz | - | 4479 | - | pF |
| C_{OSS} | Output Capacitance | | - | 629 | - | |
| C_{rSS} | Reverse Transfer Capacitance | | - | 30 | - | |
| $t_d(on)$ | Turn-on Delay Time | $V_{DS} = 60\text{ V}, V_{GEN} = 10\text{ V},$ $R_G = 3.9\ \Omega, R_L = 2\ \Omega,$ $I_{DS} = 30\text{ A}$ | - | 18 | - | nS |
| t_r | Turn-on Rise Time | | - | 35 | - | |
| $t_d(off)$ | Turn-off Delay Time | | - | 40 | - | |
| t_f | Turn-off Fall Time | | - | 26 | - | |
| Gate Charge Characteristics^b | | | | | | |
| Q_g | Total Gate Charge | $V_{GS} = 10\text{ V}, V_{DS} = 60\text{ V},$ $I_{DS} = 30\text{ A}$ | - | 73 | - | nC |
| Q_{gs} | Gate-Source Charge | | - | 26 | - | |
| Q_{gd} | Gate-Drain Charge | | - | 18 | - | |

Notes :

a : Pulse test ; pulse width $\leq 300\ \mu\text{s}$, duty cycle $\leq 2\%$

b : Guaranteed by design, not subject to production testing

7. Typical Characteristics

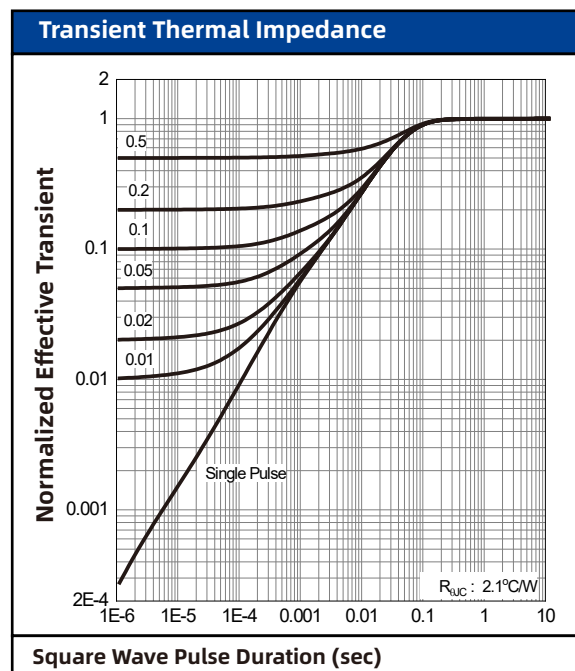
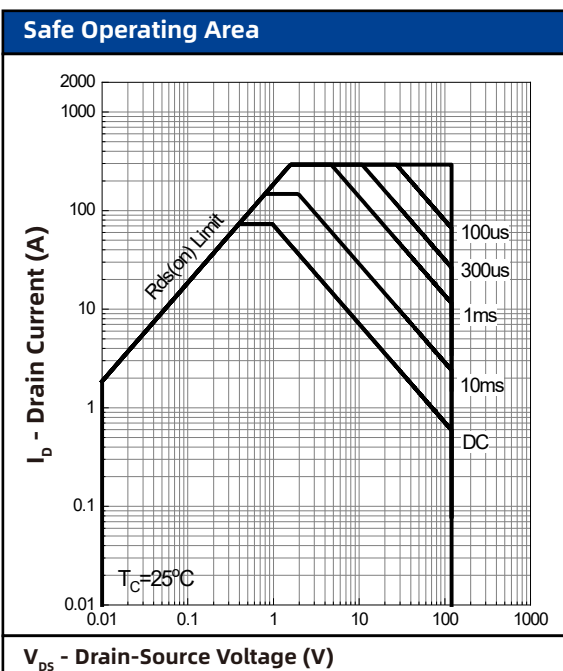
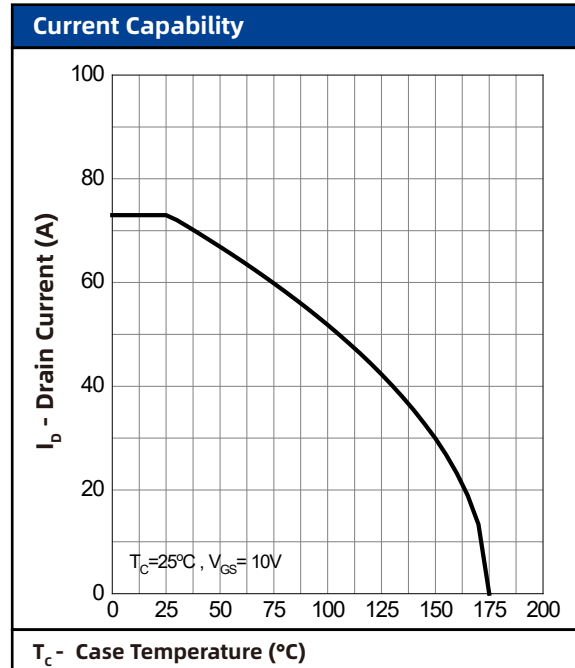
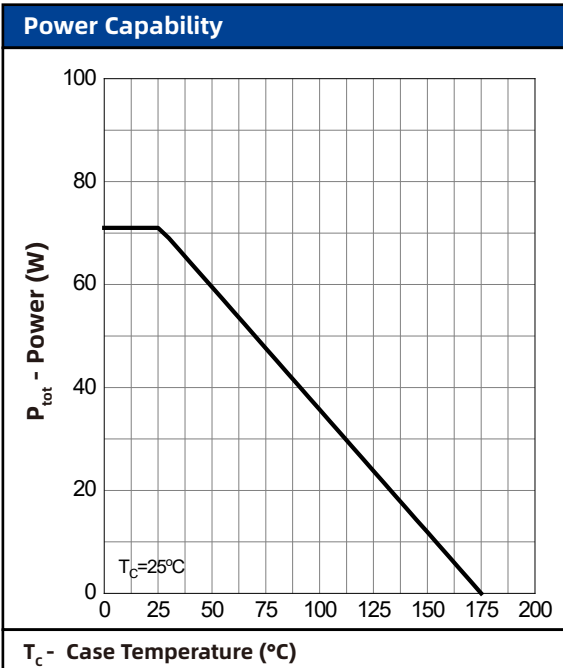

7. Typical Characteristics (cont.)

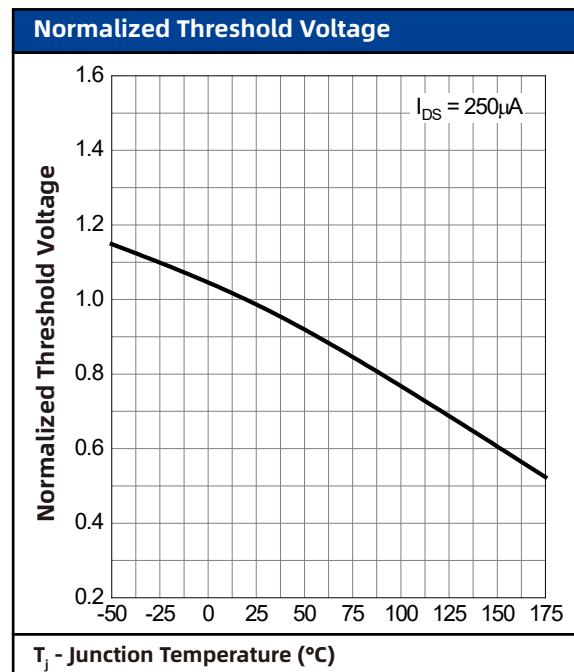
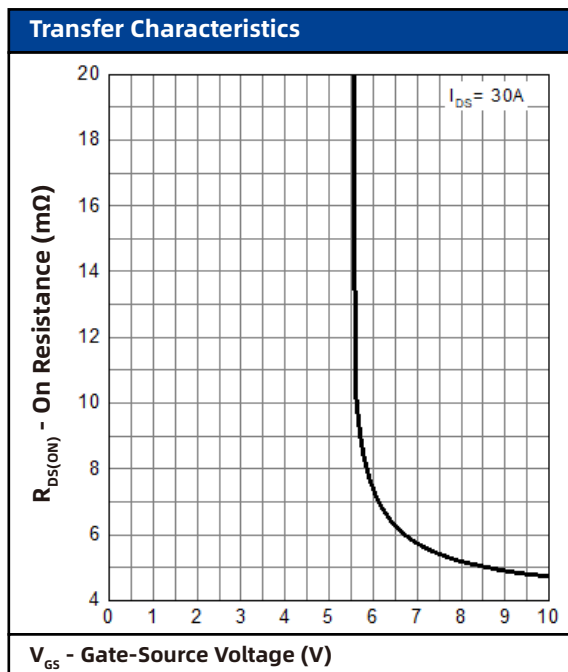
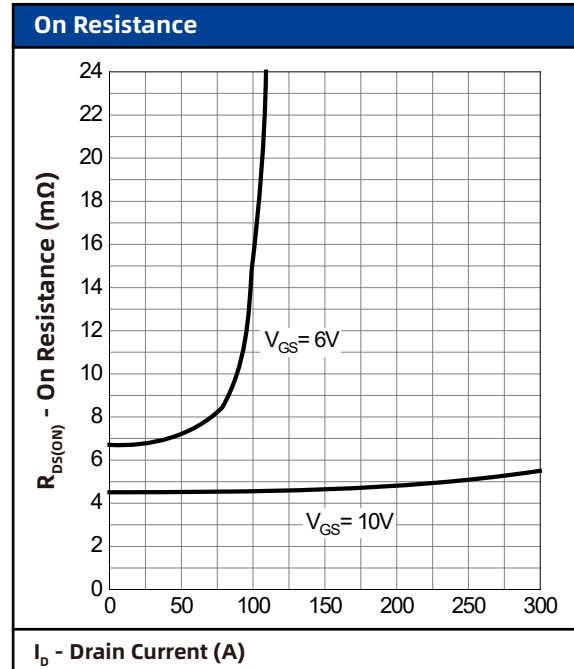
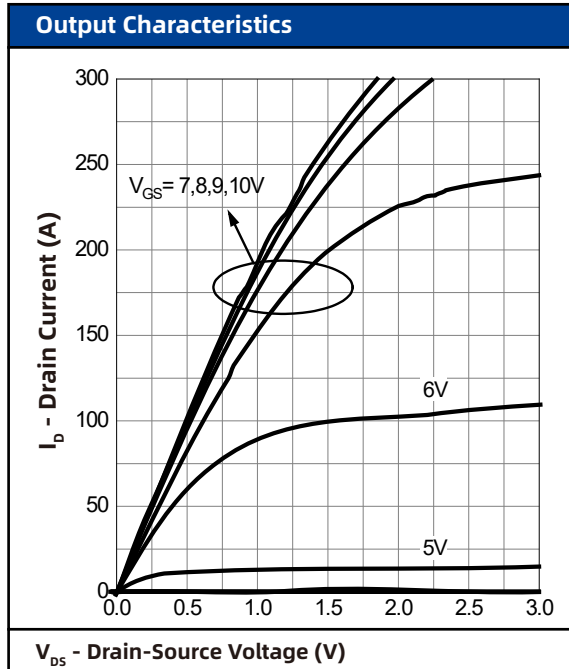

7. Typical Characteristics (cont.)

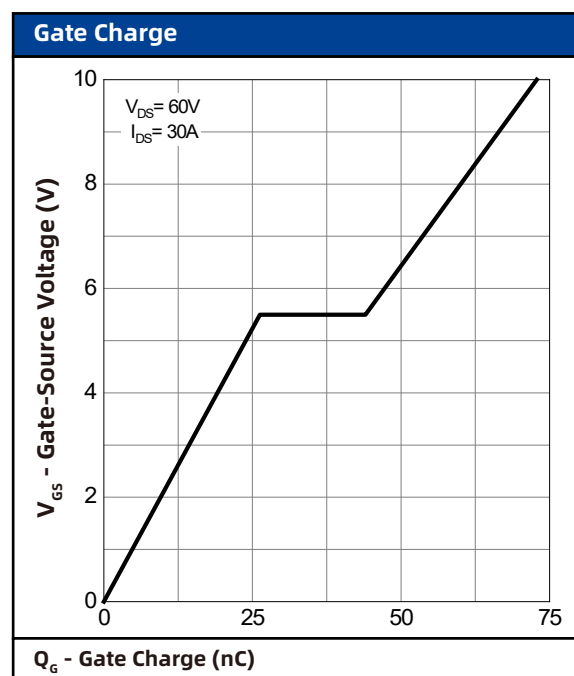
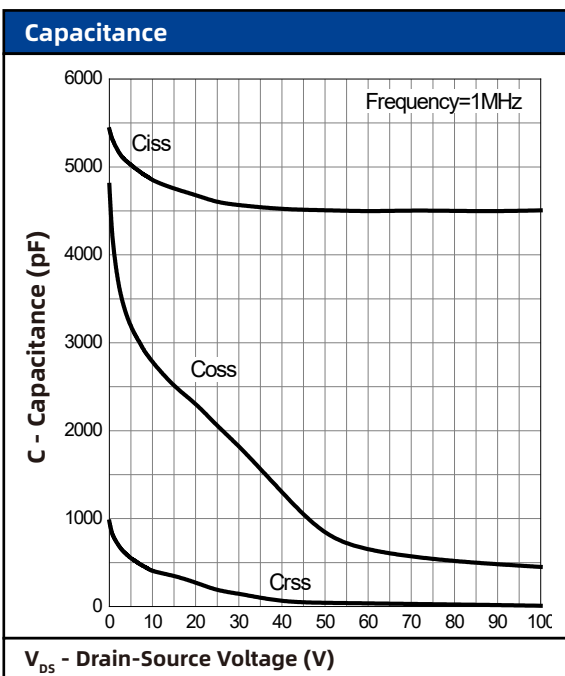
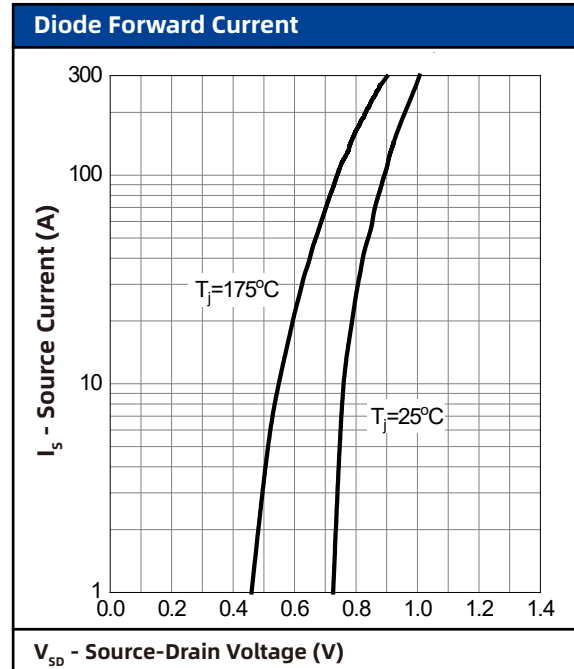
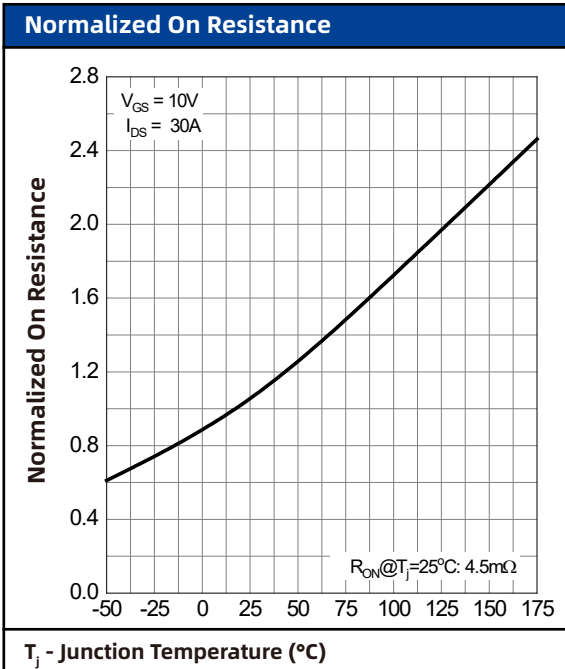

8. Package Dimensions

LFPAK5*6 Package

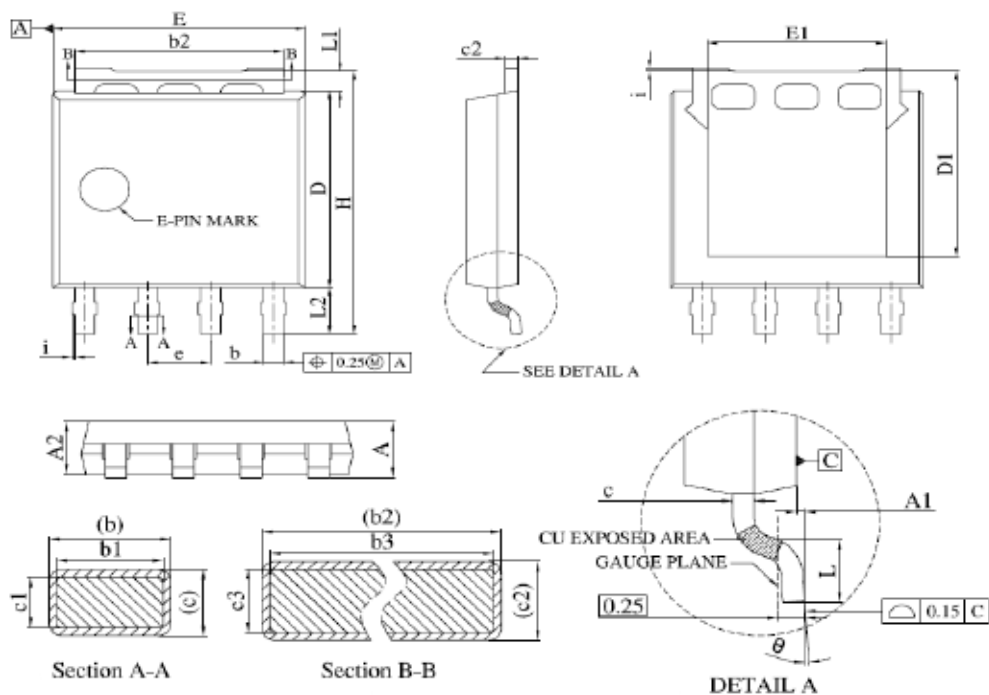

| Symbol | Dimensions In Millimeters | |
|----------|---------------------------|------|
| | Min. | Max. |
| A | 1.00 | 1.30 |
| A1 | 0.00 | 0.15 |
| A2 | 0.98 | 1.12 |
| b | 0.35 | 0.50 |
| b1 | 0.32 | 0.46 |
| b2 | 4.02 | 4.41 |
| b3 | 4.00 | 4.37 |
| c | 0.19 | 0.25 |
| c1 | 0.17 | 0.23 |
| c2 | 0.24 | 0.30 |
| c3 | 0.22 | 0.28 |
| D | 4.45 | 4.70 |
| D1 | - | 4.45 |
| E | 4.95 | 5.30 |
| E1 | 3.50 | 3.70 |
| e | 1.27BSC | |
| H | 5.95 | 6.25 |
| i | - | 0.25 |
| L | 0.40 | 0.85 |
| L1 | 0.27 | 0.57 |
| L2 | 0.80 | 1.30 |
| θ | 0° | 8° |