

## 120V N-Channel Enhancement Mode MOSFET

### 1. Product Information

#### 1.1 Features

- ◇ Advanced SGT cell design
- ◇ Low Thermal Resistance

#### 1.2 Applications

- ◇ Motor drivers
- ◇ DC - DC Converter

#### 1.3 Quick reference

- ◇  $BV \cong 120\text{ V}$
- ◇  $P_{\text{tot}} \cong 147\text{ W}$
- ◇  $I_D \cong 100\text{ A}$
- ◇  $R_{\text{DS(ON)}} \cong 5.0\text{ m}\Omega @ V_{\text{GS}} = 10\text{ V}$
- ◇  $R_{\text{DS(ON)}} \cong 7.5\text{ m}\Omega @ V_{\text{GS}} = 6\text{ V}$

### 2. Pin Description

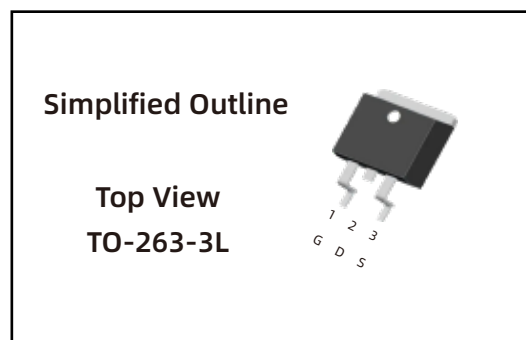
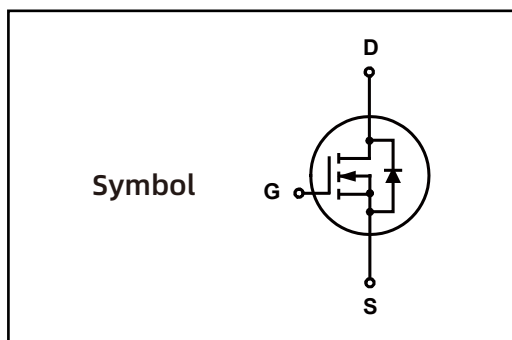

### 3. Marking Information

Product Name	Marking
LN055N120K-H	LN055N120K-H CYWWZZ XXXXXX

## 4.Limiting Values

Symbol	Parameter	Conditions	Min	Max	Unit
$V_{DS}$	Drain-Source Voltage	$T_c = 25\text{ }^\circ\text{C}$	120	-	V
$V_{GS}$	Gate-Source Voltage	$T_c = 25\text{ }^\circ\text{C}$	-	$\pm 20$	V
$I_D^*$	Drain Current ( DC )	$T_c = 25\text{ }^\circ\text{C}, V_{GS} = 10\text{ V}$	-	100	A
		$T_c = 100\text{ }^\circ\text{C}, V_{GS} = 10\text{ V}$	-	63	A
$I_{DM}^{*,**,***}$	Drain Current ( Pulsed )	$T_c = 25\text{ }^\circ\text{C}, V_{GS} = 10\text{ V}$	-	240	A
$P_{tot}$	Total Power Dissipation	$T_c = 25\text{ }^\circ\text{C}$	-	147	W
$T_{stg}$	Storage Temperature		- 55	150	$^\circ\text{C}$
$T_J$	Junction Temperature		-	150	$^\circ\text{C}$
$I_S$	Diode Forward Current	$T_c = 25\text{ }^\circ\text{C}$	-	100	A
$E_{AS}^*$	Single Pulsed Avalanche Energy	$V_{DD} = 50\text{ V}, L = 1.0\text{mH}$	-	800	mJ
$R_{\theta JA}^*$	Thermal Resistance- Junction to Ambient		-	62.5	$^\circ\text{C/W}$
$R_{\theta JC}^*$	Thermal Resistance- Junction to Case		-	0.85	

Notes :

\* Surface Mounted on 1 in<sup>2</sup> pad area,  $t \leq 10\text{ sec}$

\*\* Pulse width  $\leq 300\text{ }\mu\text{s}$ , duty cycle  $\leq 2\%$

\*\*\* limited by bonding wire

## 5.Ordering Code

Product Name	Package	Reel Size	Tape width	Quantity	Note
LN055N120K-H	T0263			800	

Note: COMTECH defines " Green " as lead-free ( RoHS compliant ) and halogen free ( Br or Cl does not exceed 900 ppm by weight in homogeneous material and total of Br and Cl does not exceed 1500 ppm by weight; Follow IEC 61249-2-21 and IPC / JEDEC J-STD-020C )

## 6. Electrical Characteristics ( $T_A=25^\circ$ Unless Otherwise Noted )

Symbol	Parameter	Conditions	Min	Typ	Max	Unit
<b>Static Characteristics</b>						
$BV_{DSS}$	Drain-Source Breakdown Voltage	$V_{GS} = 0\text{ V}, I_D = 250\ \mu\text{A}$	120	-	-	V
$V_{GS(th)}$	Gate Threshold Voltage	$V_{DS} = V_{GS}, I_{DS} = 250\ \mu\text{A}$	2	-	4	V
$I_{DSS}$	Zero Gate Voltage Source Current	$V_{DS} = 96\text{ V}, V_{GS} = 0\text{ V}$	-	-	1	$\mu\text{A}$
$I_{GSS}$	Gate Leakage Current	$V_{GS} = \pm 20\text{ V}, V_{DS} = 0\text{ V}$	-	-	$\pm 100$	nA
$R_{DS(on)}^a$	Drain-Source On-State Resistance	$V_{GS} = 10\text{ V}, I_D = 50\text{ A}$	-	4.6	5.0	m $\Omega$
	Drain-Source On-State Resistance	$V_{GS} = 6\text{ V}, I_D = 30\text{ A}$	-	6.9	7.5	
<b>Diode Characteristics</b>						
$V_{SD}^a$	Diode Forward Voltage	$I_{SD} = 50\text{ A}, V_{GS} = 0\text{ V}$	-	-	1.3	V
$t_{rr}$	Reverse Recovery Time	$I_{SD} = 50\text{ A}$	-	100	-	nS
$Q_{rr}$	Reverse Recovery Charge	$dI_{SD}/dt = 100\text{ A}/\mu\text{s}$	-	307	-	nC
<b>Dynamic Characteristics<sup>b</sup></b>						
$C_{iss}$	Input Capacitance	$V_{GS} = 0\text{ V}, V_{DS} = 60\text{ V}$ Frequency = 1 MHz	-	4903	-	pF
$C_{oss}$	Output Capacitance		-	566	-	
$C_{riss}$	Reverse Transfer Capacitance		-	47	-	
$t_d(on)$	Turn-on Delay Time	$V_{DS} = 60\text{ V}, V_{GEN} = 10\text{ V},$ $R_G = 3.9\ \Omega, R_L = 1.2\ \Omega,$ $I_D = 50\text{ A}$	-	18	-	nS
$t_r$	Turn-on Rise Time		-	71	-	
$t_d(off)$	Turn-off Delay Time		-	51	-	
$t_f$	Turn-off Fall Time		-	79	-	
<b>Gate Charge Characteristics<sup>b</sup></b>						
Qg	Total Gate Charge	$V_{GS} = 10\text{ V}, V_{DS} = 60\text{ V},$ $I_{DS} = 50\text{ A}$	-	81	-	nC
Qgs	Gate-Source Charge		-	28	-	
Qgd	Gate-Drain Charge		-	18	-	

Notes :

a : Pulse test ; pulse width  $\leq 300\ \mu\text{s}$ , duty cycle  $\leq 2\%$

b : Guaranteed by design, not subject to production testing

## 7. Typical Characteristics

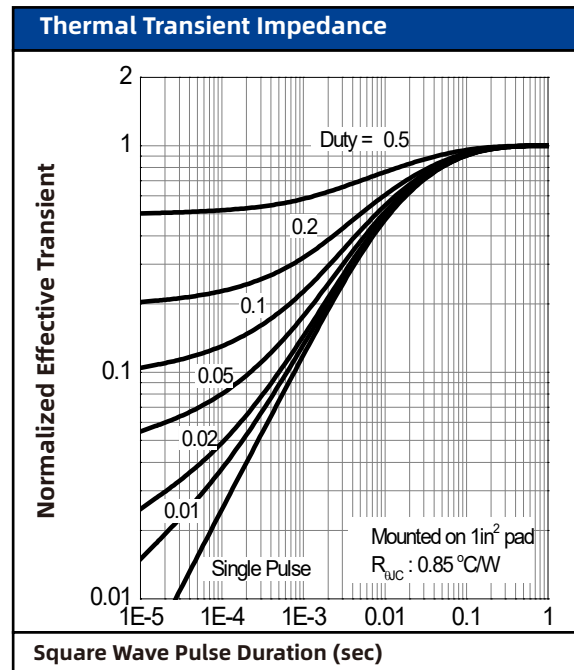
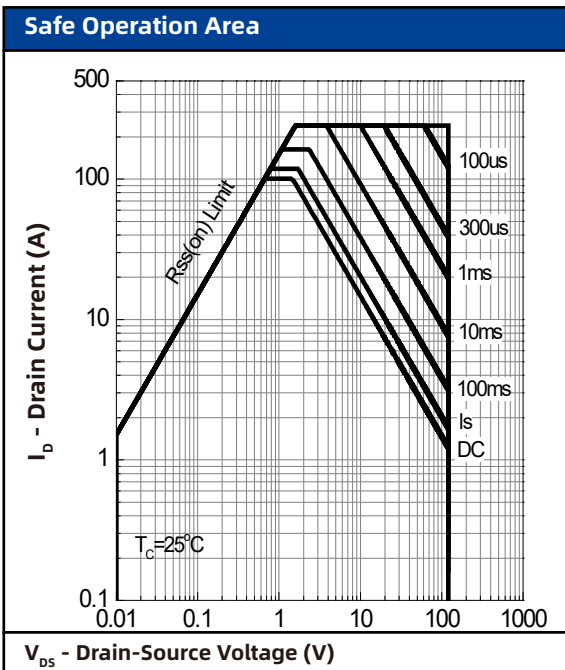
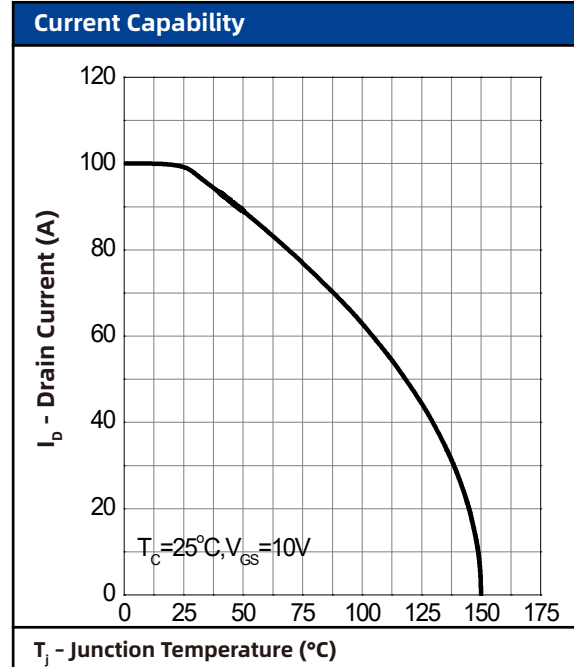
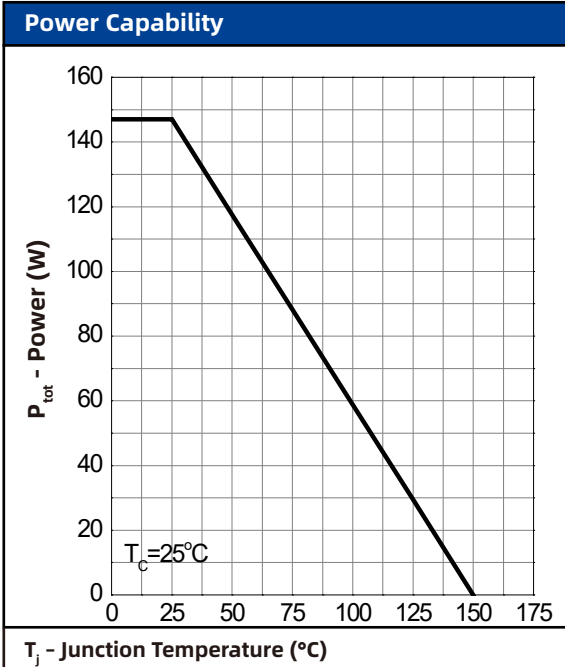

## 7. Typical Characteristics (cont.)

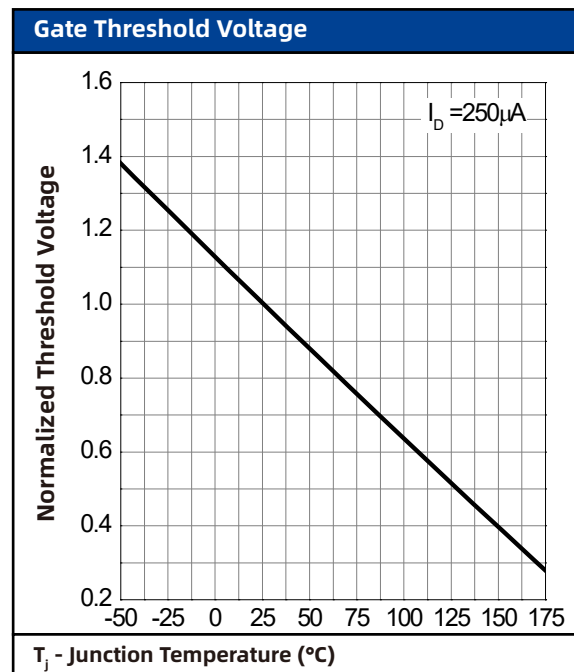
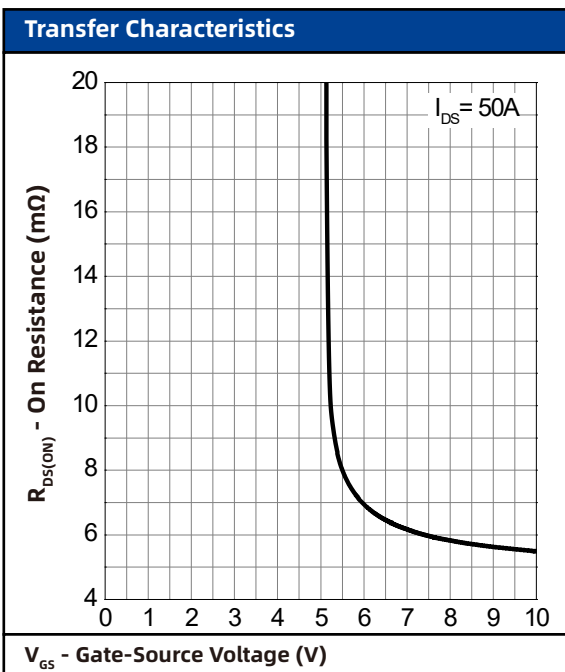
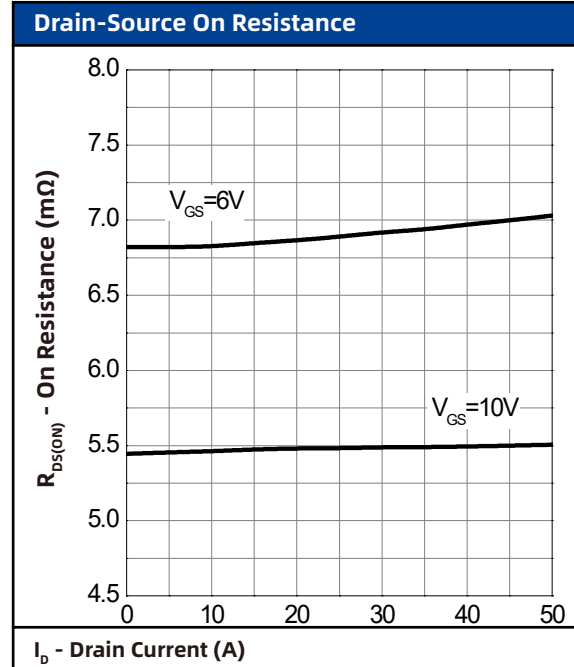
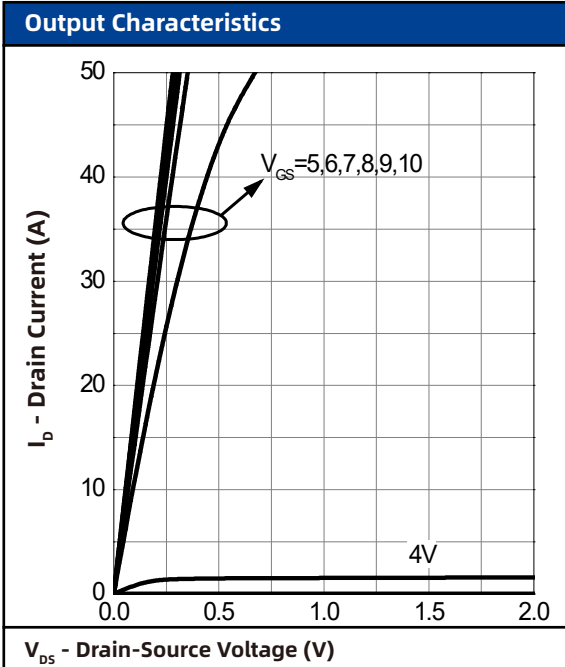

## 7. Typical Characteristics (cont.)

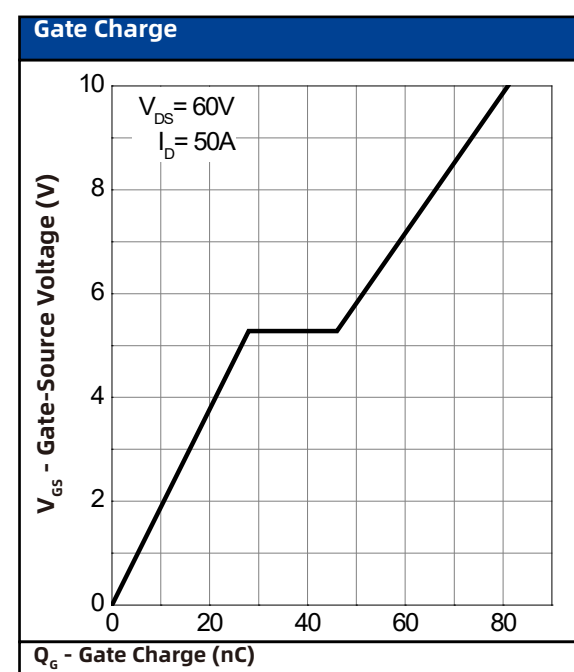
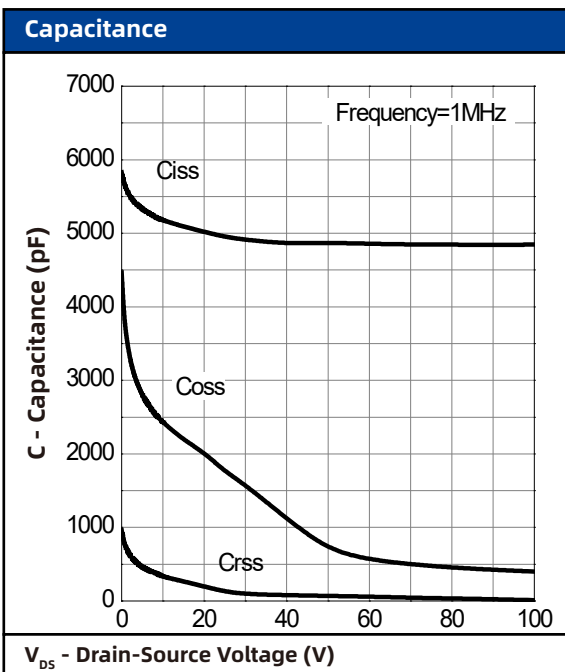
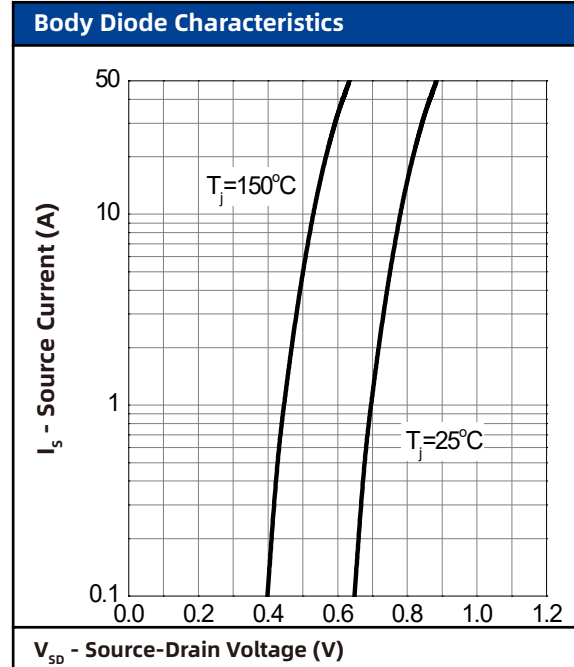
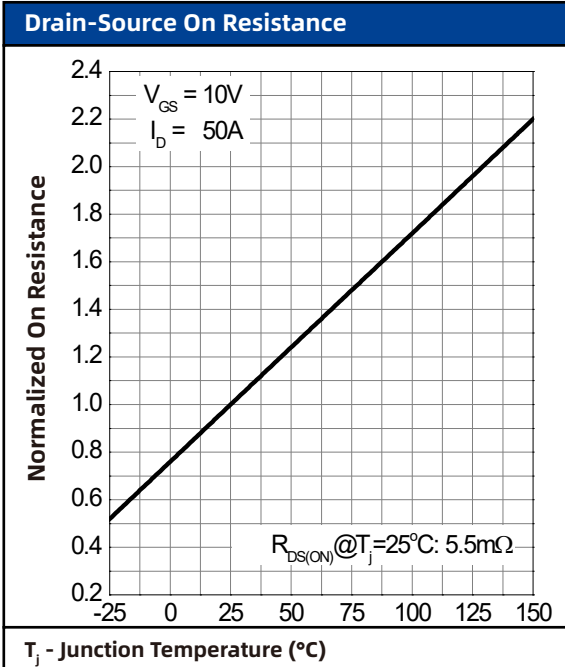

## 8. Package Dimensions

T0263-3L

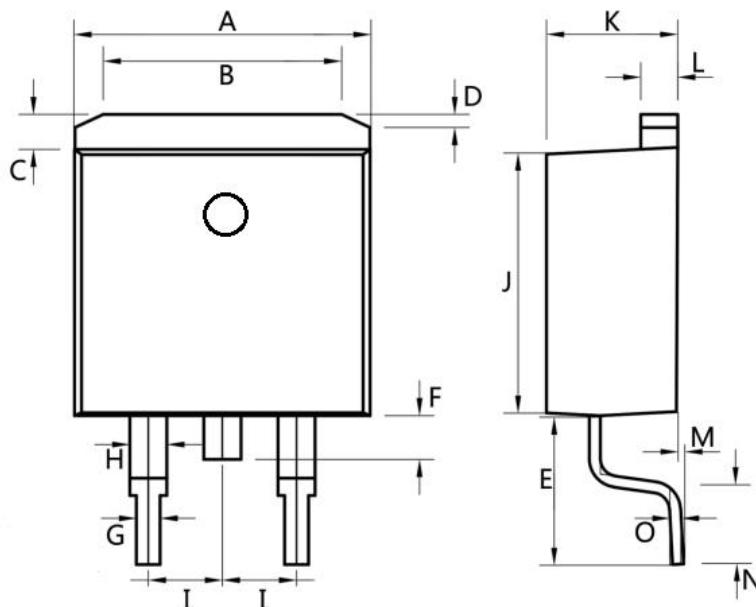

Symbol	Dimensions In Millimeters	
	MIN.	MAX.
A	9.8	10.2
B	6.1	6.7
C	1.1	1.4
D	0.5	1.0
E	4.6	5.0
F	1.4	1.6
G	0.7	0.9
H	1.17	0.37
I	Typ2.54	
J	9	9.2
K	4.3	4.7
L	1.25	1.35
M	0.02	0.23
N	2.2	2.8
O	0.45	0.55