

-40V P-Channel Enhancement Mode MOSFET

1. Product Information

1.1 Features

- ◇ Surface-mounted package
- ◇ Advanced trench cell design

1.2 Applications

- ◇ LCD TV appliances
- ◇ LCDM appliances
- ◇ High power inverter system

1.3 Quick reference

- ◇ $BV \cong -40\text{ V}$
- ◇ $P_{\text{tot}} \cong 300\text{ W}$
- ◇ $I_D \cong -180\text{ A}$
- ◇ $R_{\text{DS(ON)}} \cong 2.5\text{ m}\Omega @ V_{\text{GS}} = -10\text{ V}$
- ◇ $R_{\text{DS(ON)}} \cong 4.2\text{ m}\Omega @ V_{\text{GS}} = -4.5\text{ V}$

2. Pin Description

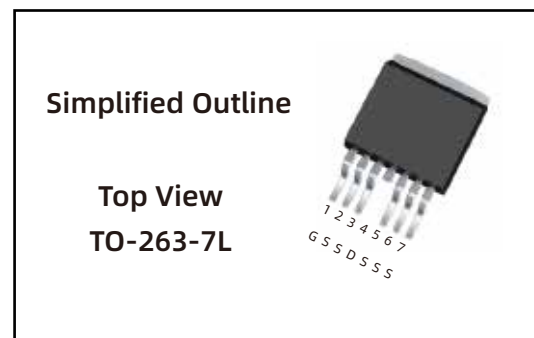
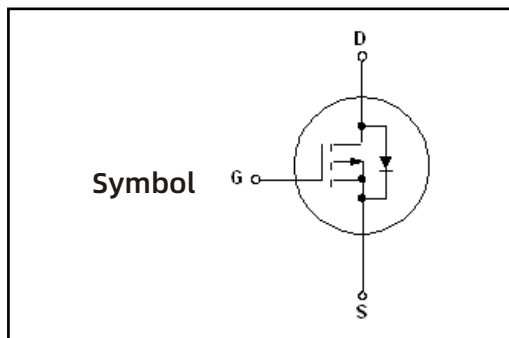

3. Marking Information

Product Name	Marking
LN018P040D	LN018P040D AYWWZZ XXXXXX

4.Limiting Values

Symbol	Parameter	Conditions	Min	Max	Unit
V_{DS}	Drain-Source Voltage	$T_C = 25\text{ }^\circ\text{C}$	-	-40	V
V_{GS}	Gate-Source Voltage	$T_C = 25\text{ }^\circ\text{C}$	-	± 20	V
$I_D^{*,***}$	Drain Current (DC)	$T_C = 25\text{ }^\circ\text{C}, V_{GS} = -10\text{ V}$	-	-180	A
		$T_C = 100\text{ }^\circ\text{C}, V_{GS} = -10\text{ V}$	-	-166	A
I_{DM}^*	Drain Current (Pulsed)	$T_C = 25\text{ }^\circ\text{C}, V_{GS} = -10\text{ V}$	-	-700	A
P_{tot}	Drain power dissipation	$T_C = 25\text{ }^\circ\text{C}$	-	300	W
T_{stg}	Storage Temperature		-55	175	$^\circ\text{C}$
T_J	Junction Temperature		-	175	$^\circ\text{C}$
I_S	Continuous-Source Current	$T_C = 25\text{ }^\circ\text{C}$	-	-180	A
I_{AS}	Single Pulsed Avalanche Current	$V_{DD} = -40\text{ V}, L = 0.1\text{ mH}$	-	-110	A
E_{AS}	Single Pulsed Avalanche Energy	$V_{DD} = -40\text{ V}, L = 1.0\text{ mH}$		612	mJ
$R_{\theta JA}^{**}$	Thermal Resistance- Junction to Ambient		-	42	$^\circ\text{C/W}$
$R_{\theta JC}^{**}$	Thermal Resistance- Junction to Case		-	0.5	

Notes :

- * Pulse width $\leq 300\text{ }\mu\text{s}$, duty cycle $\leq 2\%$
- ** Surface Mounted on 1 in² pad area, $t \leq 10\text{ sec}$
- *** Limited by bonding wire

5.Ordering Code

Product Name	Package	Reel Size	Tape width	Quantity	Note
LN018P040D	TO263-7L(D2-PAK)			800	

Note: COMTECH defines " Green " as lead-free (RoHS compliant) and halogen free (Br or Cl does not exceed 900 ppm by weight in homogeneous material and total of Br and Cl does not exceed 1500 ppm by weight;

Follow IEC 61249-2-21 and IPC / JEDEC J-STD-020C)

6. Electrical Characteristics (TA=25 ° Unless Otherwise Noted)

Symbol	Parameter	Conditions	Min	Typ	Max	Unit
Static Characteristics						
BV_{DSS}	Drain-Source Breakdown Voltage	$V_{GS} = 0\text{ V}, I_{DS} = -250\ \mu\text{A}$	-40	-	-	V
$V_{GS(th)}$	Gate Threshold Voltage	$V_{DS} = V_{GS}, I_{DS} = -250\ \mu\text{A}$	-1	-	-2.5	V
I_{DSS}	Drain Leakage Current	$V_{DS} = -32\text{ V}, V_{GS} = 0\text{ V}$	-	-	-1	μA
I_{GSS}	Gate Leakage Current	$V_{DS} = 0\text{ V}, V_{GS} = \pm 20\text{ V}$	-	-	± 100	nA
$R_{DS(on)}^a$	On-State Resistance	$V_{GS} = -10\text{ V}, I_{DS} = -50\text{ A}$	1.8	2.0	2.5	m Ω
		$V_{GS} = -4.5\text{ V}, I_{DS} = -30\text{ A}$	3.3	3.8	4.2	
Diode Characteristics						
V_{SD}^a	Diode Forward Voltage	$I_{SD} = -50\text{ A}, V_{GS} = 0\text{ V}$	-	-	-1.3	V
t_{rr}	Reverse Recovery Time	$I_{DS} = -50\text{ A}, V_{GS} = 0\text{ V}$	-	28	-	nS
Q_{rr}	Reverse Recovery Charge	$dI_{SD}/dt = 100\text{ A}/\mu\text{s}$	-	26	-	nC
Dynamic Characteristics^b						
C_{ISS}	Input Capacitance	$V_{GS} = 0\text{ V}, V_{DS} = -20\text{ V}$ Frequency = 1 MHz	-	16177	-	pF
C_{OSS}	Output Capacitance		-	1067	-	
C_{rSS}	Reverse Transfer Capacitance		-	301	-	
$t_d(on)$	Turn-on Delay Time	$V_{DS} = -20\text{ V}, V_{GEN} = -10\text{ V},$ $R_G = 3.9\ \Omega, R_L = 0.4\ \Omega,$ $I_{DS} = -50\text{ A}$	-	18	-	nS
t_r	Turn-on Rise Time		-	124	-	
$t_d(off)$	Turn-off Delay Time		-	337	-	
t_f	Turn-off Fall Time		-	140	-	
Gate Charge Characteristics^b						
Qg	Total Gate Charge	$V_{DS} = -20\text{ V}, V_{GS} = -10\text{ V},$ $I_{DS} = -20\text{ A}$	-	276	-	nC
Qgs	Gate-Source Charge		-	65	-	
Qgd	Gate-Drain Charge		-	35	-	

Notes :

a : Pulse test ; pulse width $\leq 300\ \mu\text{s}$, duty cycle $\leq 2\%$

b : Guaranteed by design, not subject to production testing

7. Typical Characteristics

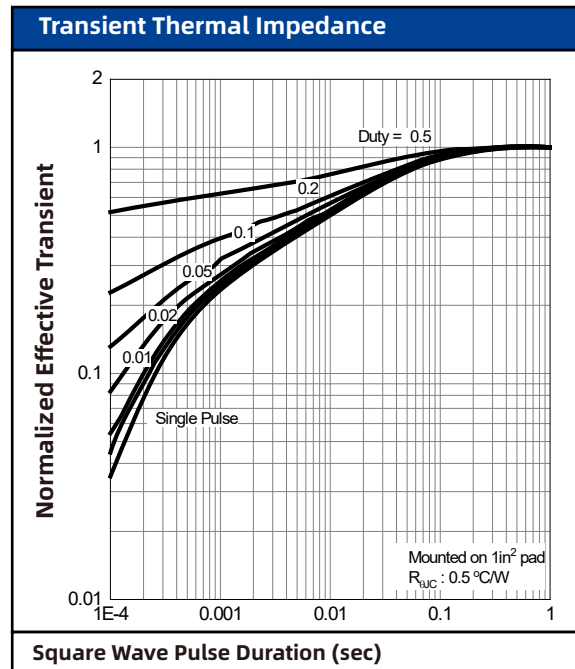
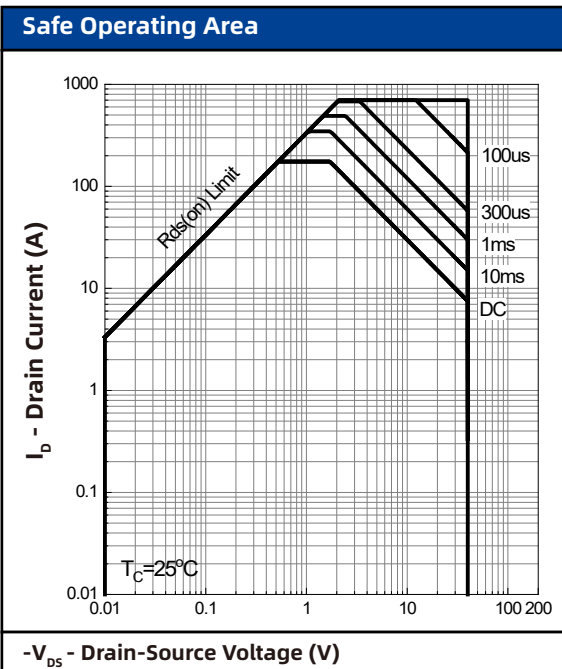
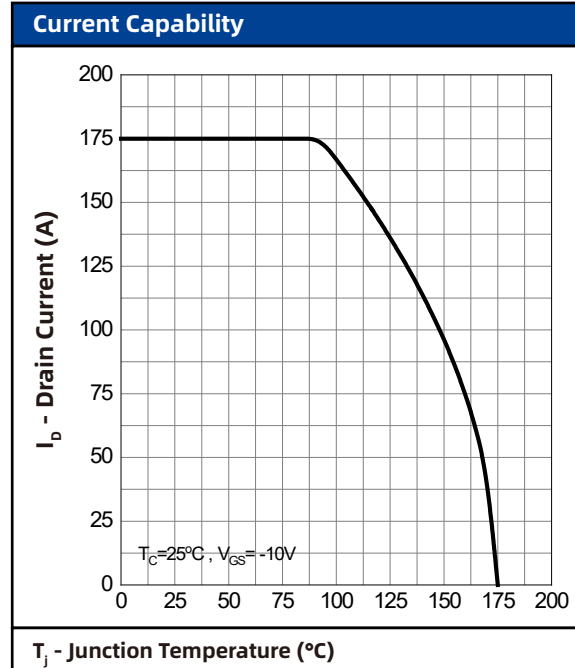
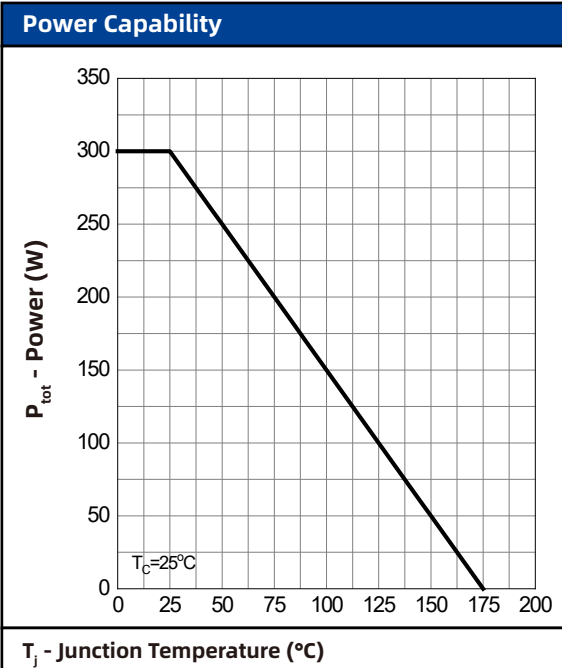

7. Typical Characteristics (cont.)

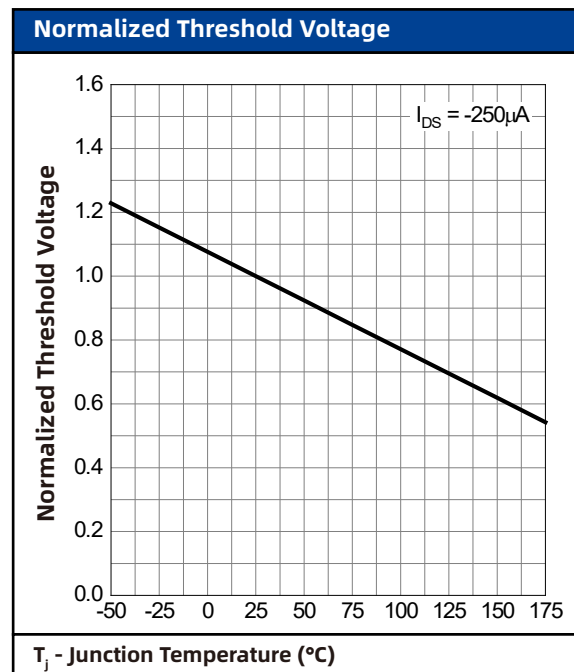
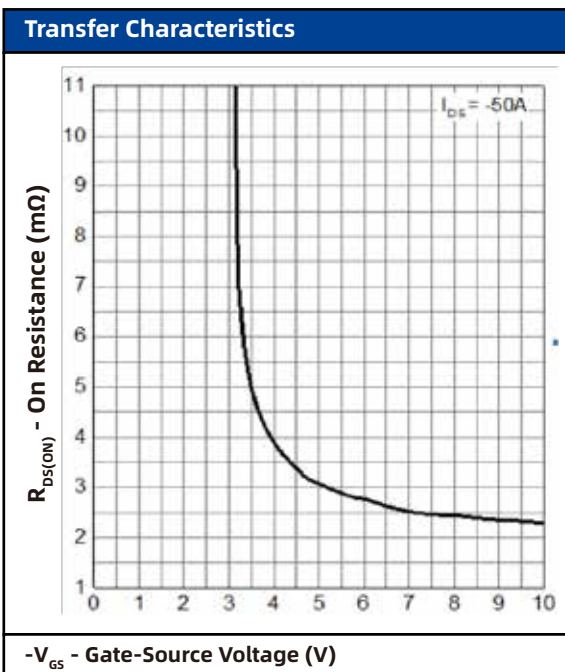
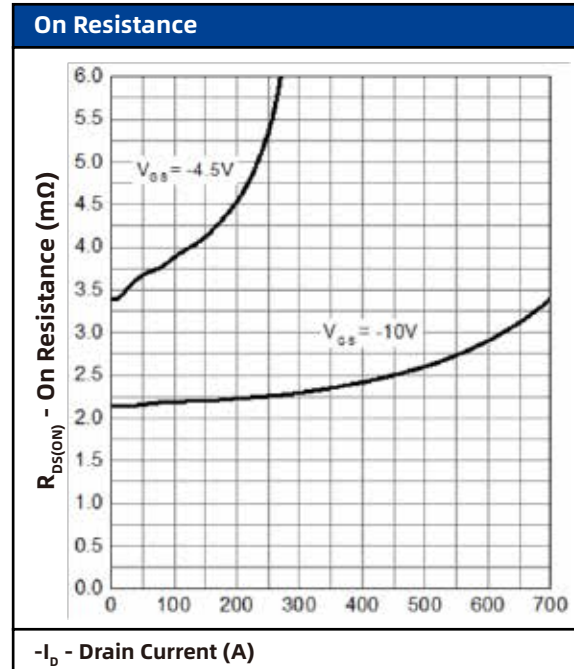
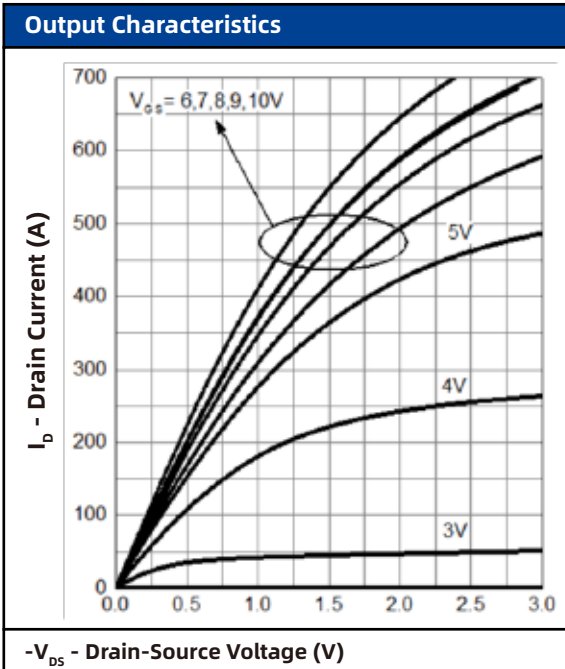

7. Typical Characteristics (cont.)

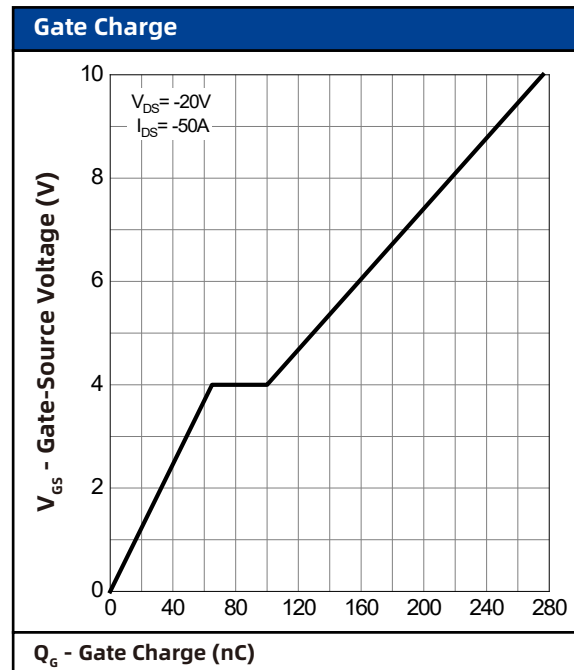
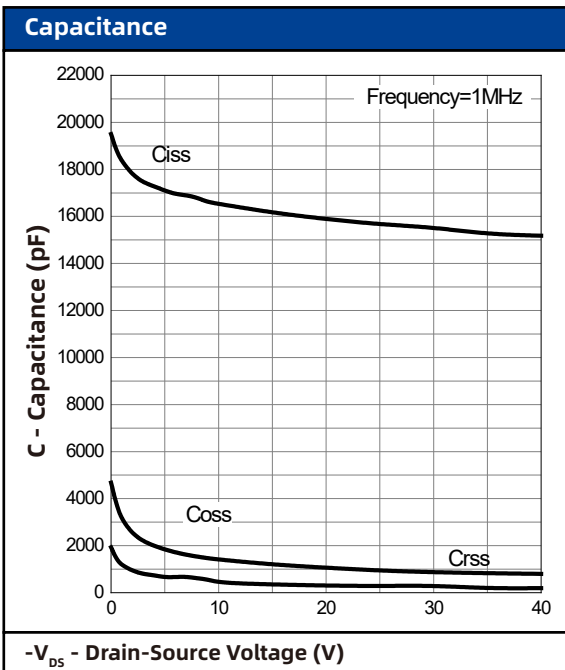
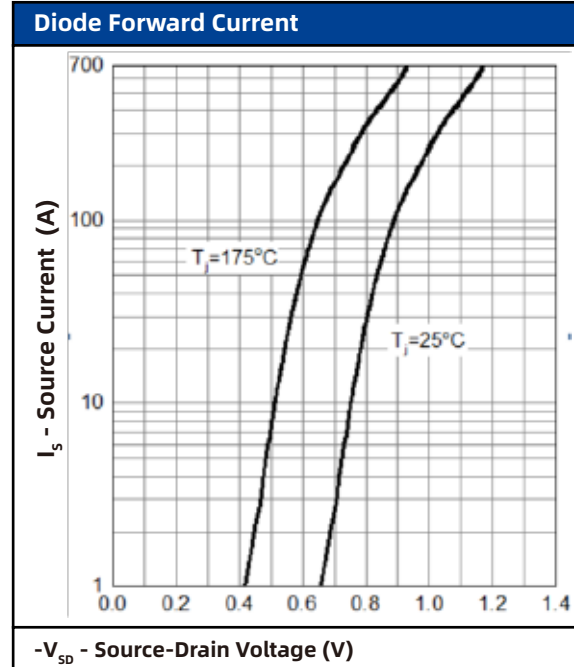
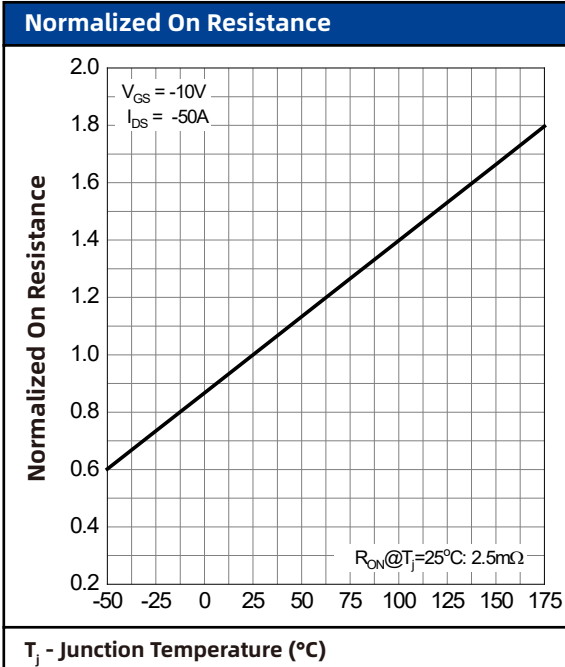

8. Package Dimensions

TO263-7L Package

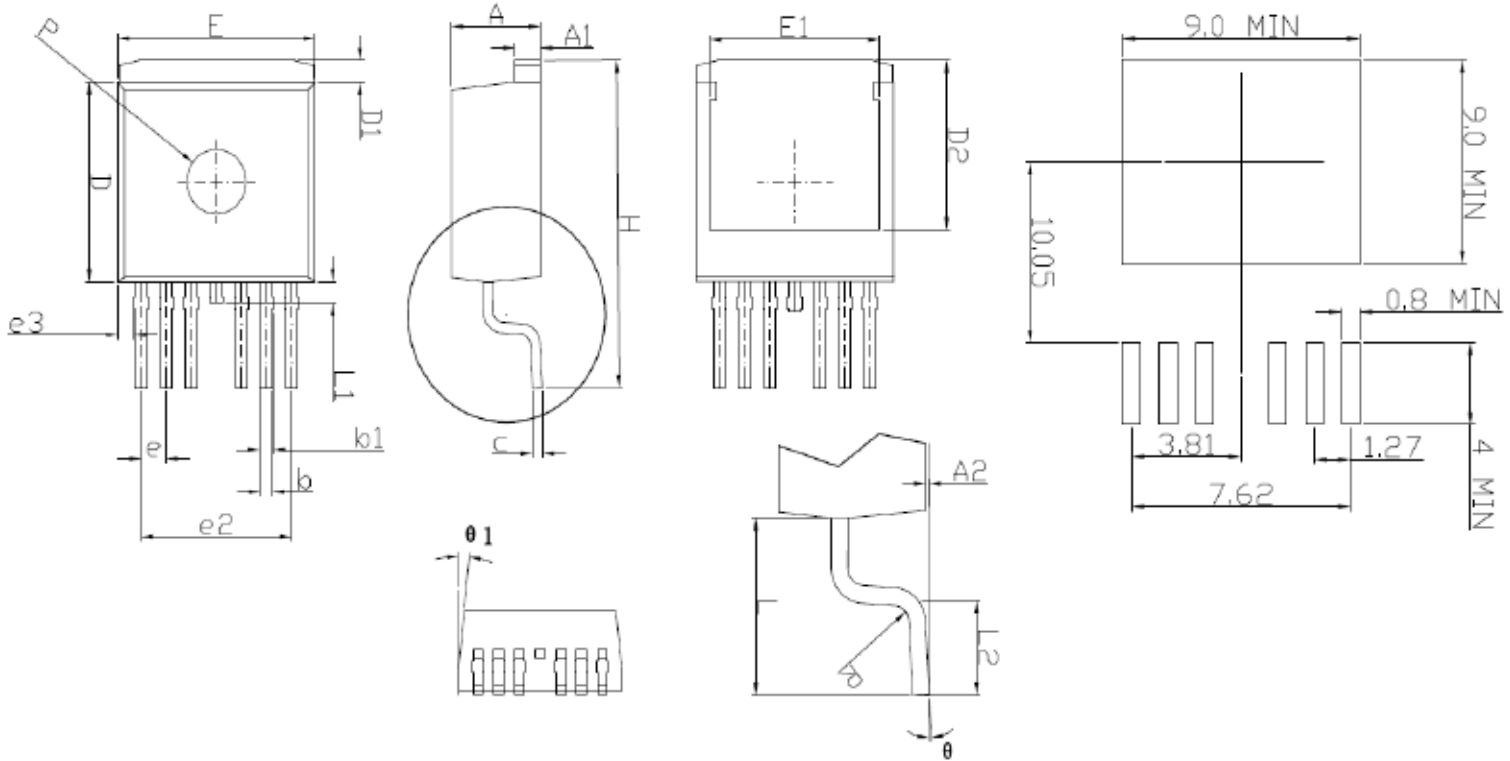

Symbol	Dimensions In Millimeters	
	Min	Max
A	4.30	4.70
A1	1.20	1.40
A2	0.05	0.30
b	0.50	0.70
b1	0.50	0.90
c	0.40	0.60
D	9.05	9.45
D1	0.70	1.30
D2	7.35	8.35
E	9.80	10.20
E1	8.10	9.10
e	1.07	1.47
e2	7.32	7.92
e3	0.64	1.04
H	14.65	15.65
L	4.47	5.47
L1	0.90	1.50
L2	2.20	2.80
θ	0°	8°
θ1	0°	10°
φ	2.70	3.30