

## 100 V N-Channel Enhancement Mode MOSFET

### 1. Product Information

#### 1.1 Features

- ◇ Surface-mounted package
- ◇ Advanced SGT cell design

#### 1.2 Applications

- ◇ Power Tool appliances
- ◇ BMS appliances
- ◇ High power inverter system

#### 1.3 Quick reference

- ◇  $BV \cong 100\text{ V}$
- ◇  $P_{\text{tot}} \cong 500\text{ W}$
- ◇  $I_D \cong 500\text{ A}$
- ◇  $R_{\text{DS(ON)}} \cong 1.6\text{ m}\Omega @ V_{\text{GS}} = 10\text{ V}$

### 2. Pin Description

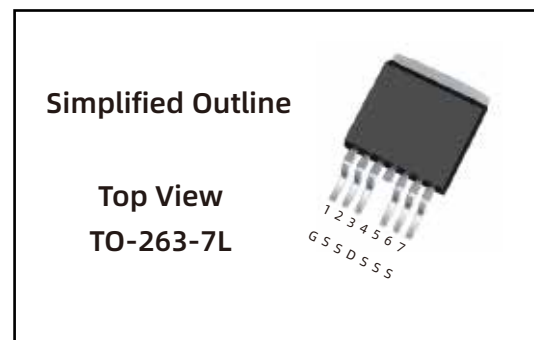
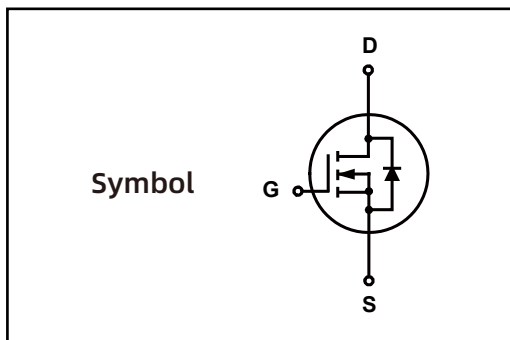

### 3. Marking Information

Product Name	Marking
LN015N100D	LN015N100D BYWW02 XXXXXX

## 4.Limiting Values

Symbol	Parameter	Conditions	Min	Max	Unit
$V_{DS}$	Drain-Source Voltage	$T_C = 25\text{ }^\circ\text{C}$	100	-	V
$V_{GS}$	Gate-Source Voltage	$T_C = 25\text{ }^\circ\text{C}$	-	$\pm 20$	V
$I_D$	Drain Current ( DC )	$T_C = 25\text{ }^\circ\text{C}, V_{GS} = 10\text{ V}$	-	500	A
		$T_C = 100\text{ }^\circ\text{C}, V_{GS} = 10\text{ V}$	-	367	A
$I_{DM}^*$	Drain Current ( Pulsed )	$T_C = 25\text{ }^\circ\text{C}, V_{GS} = 10\text{ V}$	-	1200	A
$P_{tot}$	Drain power dissipation	$T_C = 25\text{ }^\circ\text{C}$	-	500	W
$T_{stg}$	Storage Temperature		-55	175	$^\circ\text{C}$
$T_J$	Junction Temperature		-	175	$^\circ\text{C}$
$I_S$	Continuous-Source Current	$T_C = 25\text{ }^\circ\text{C}$	-	500	A
$E_{AS}$	Single Pulsed Avalanche Energy	$V_{DD} = 40\text{ V}, L = 0.5\text{ mH}$	-	2900	mJ
$R_{\theta JA}^{**}$	Thermal Resistance- Junction to Ambient		-	32	$^\circ\text{C/W}$
$R_{\theta JC}^{**}$	Thermal Resistance- Junction to Case		-	0.45	

Notes :

\* Pulse width  $\leq 300\text{ s}$ , duty cycle  $\leq 2\%$

\*\* Surface Mounted on minimum footprint pad area.

\*\*\* Limited by bonding wire

## 5.Ordering Code

Product Name	Package	Reel Size	Tape width	Quantity	Note
LN015N100D	TO263-7L(D2-PAK)			800	

Note: COMTECH defines " Green " as lead-free ( RoHS compliant ) and halogen free ( Br or Cl does not exceed 900 ppm by weight in homogeneous material and total of Br and Cl does not exceed 1500 ppm by weight; Follow IEC 61249-2-21 and IPC / JEDEC J-STD-020C )

## 6. Electrical Characteristics ( $T_A=25^\circ$ Unless Otherwise Noted )

Symbol	Parameter	Conditions	Min	Typ	Max	Unit
<b>Static Characteristics</b>						
$BV_{DDs}$	Drain-Source Breakdown Voltage	$V_{GS} = 0\text{ V}, I_{DS} = 250\ \mu\text{A}$	100	-	-	V
$V_{GS(th)}$	Gate Threshold Voltage	$V_{DS} = V_{GS}, I_{DS} = 250\ \mu\text{A}$	2	-	4	V
$I_{DDs}$	Drain Leakage Current	$V_{DS} = 100\text{V}, V_{GS} = 0\text{ V}$	-	-	1	$\mu\text{A}$
$I_{GSS}$	Gate Leakage Current	$V_{GS} = 0\text{ V}, V_{GS} = \pm 20\text{ V}$	-	-	$\pm 100$	nA
$R_{DS(ON)}^a$	On-State Resistance	$V_{GS} = 10\text{ V}, I_{DS} = 50\text{ A}$	-	1.4	1.6	m $\Omega$
<b>Diode Characteristics</b>						
$V_{SD}^a$	Diode Forward Voltage	$I_{SD} = 50\text{ A}, V_{GS} = 0\text{ V}$	-	-	1.2	V
$t_{rr}$	Reverse Recovery Time	$I_{DS} = 50\text{ A}, V_{GS} = 0\text{ V}$	-	100	-	nS
$Q_{rr}$	Reverse Recovery Charge	$dI_{SD}/dt = 100\text{ A}/\mu\text{s}$	-	280	-	nC
<b>Dynamic Characteristics<sup>b</sup></b>						
$C_{ISS}$	Input Capacitance	$V_{GS} = 0\text{ V}, V_{DS} = 50\text{ V}$ Frequency = 1 MHz	-	14260	-	pF
$C_{OSS}$	Output Capacitance		-	1715	-	
$C_{rSS}$	Reverse Transfer Capacitance		-	328	-	
$t_d(on)$	Turn-on Delay Time	$V_{DS} = 50\text{V}, V_{GEN} = 10\text{ V},$ $R_G = 4.5\Omega, R_L = 1\ \Omega,$ $I_{DS} = 50\text{ A}$	-	34	-	nS
$t_r$	Turn-on Rise Time		-	26	-	
$t_d(off)$	Turn-off Delay Time		-	78	-	
$t_f$	Turn-off Fall Time		-	30	-	
<b>Gate Charge Characteristics<sup>b</sup></b>						
Qg	Total Gate Charge	$V_{DS} = 50\text{ V}, V_{GS} = 10\text{ V},$ $I_{DS} = 50\text{ A}$	-	224		nC
Qgs	Gate-Source Charge		-	80		
Qgd	Gate-Drain Charge		-	38		

Notes :

a : Pulse test ; pulse width  $\leq 300\text{ s}$ , duty cycle  $\leq 2\%$

b : Guaranteed by design, not subject to production testing

## 7. Typical Characteristics

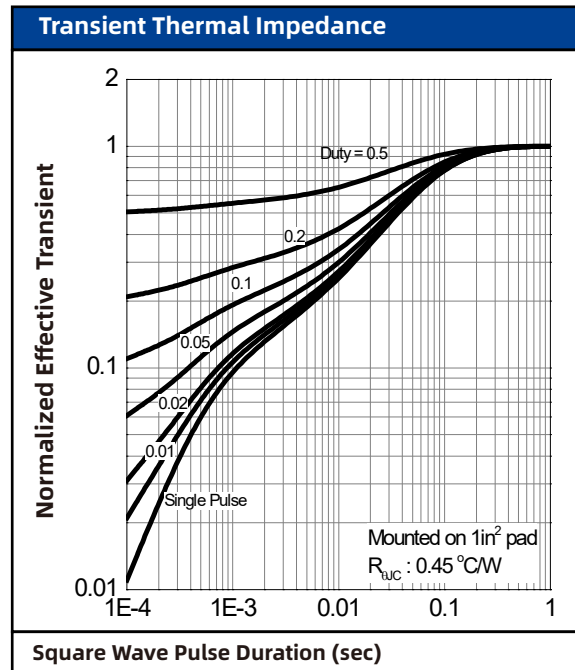
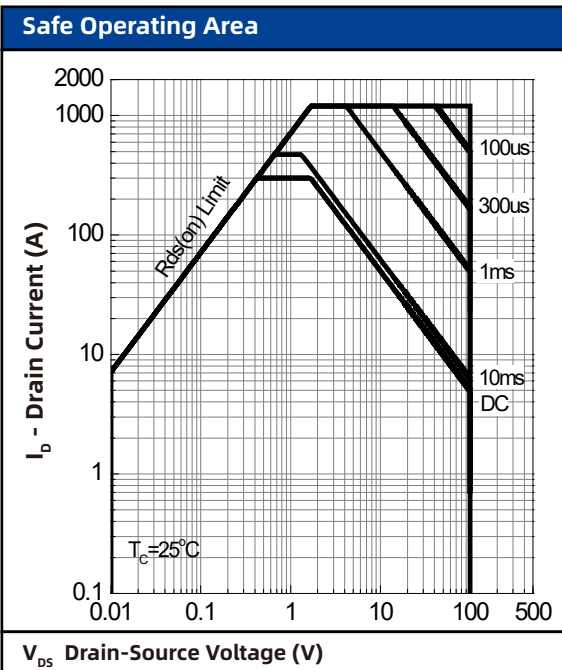
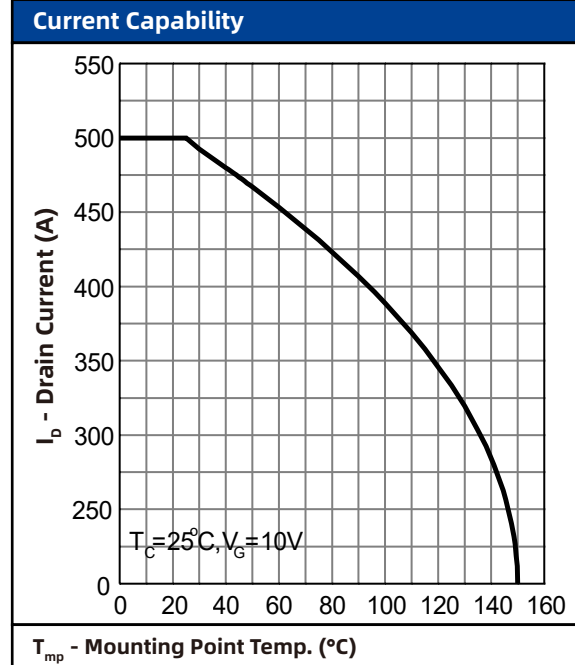
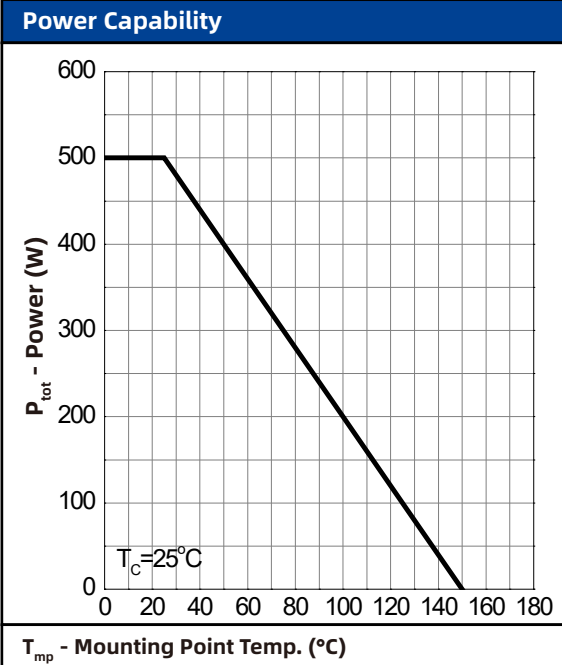

## 7. Typical Characteristics (cont.)

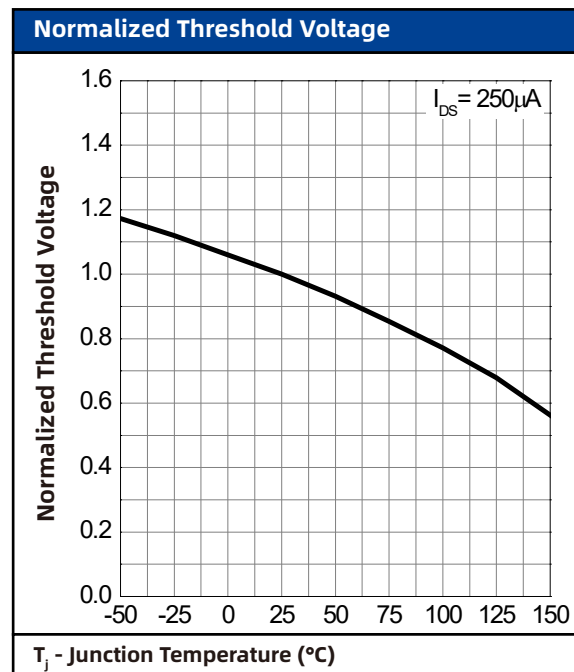
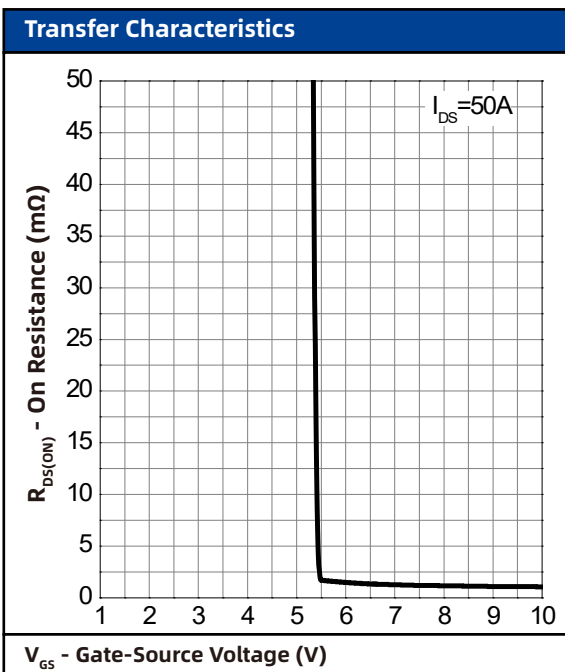
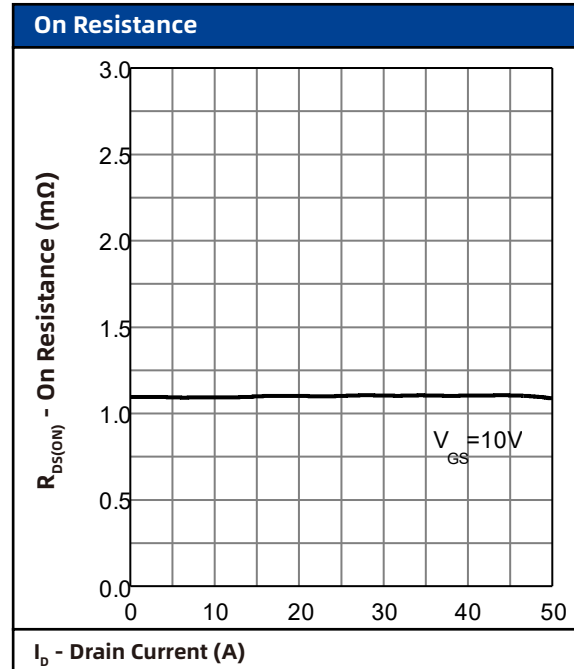
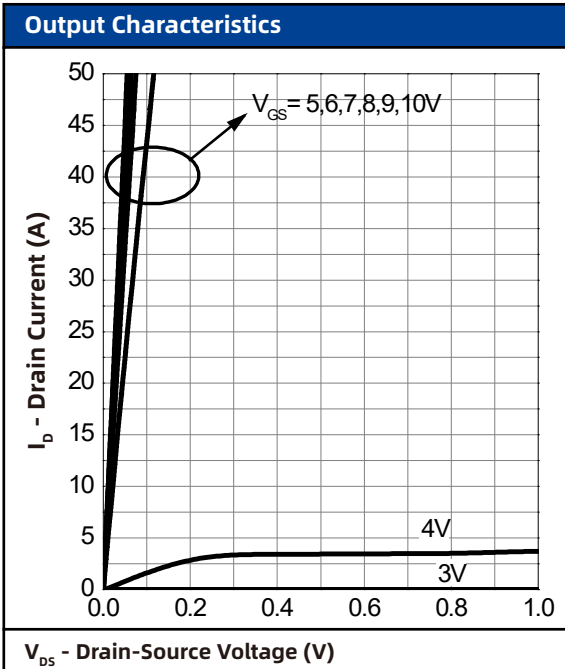

## 7. Typical Characteristics (cont.)

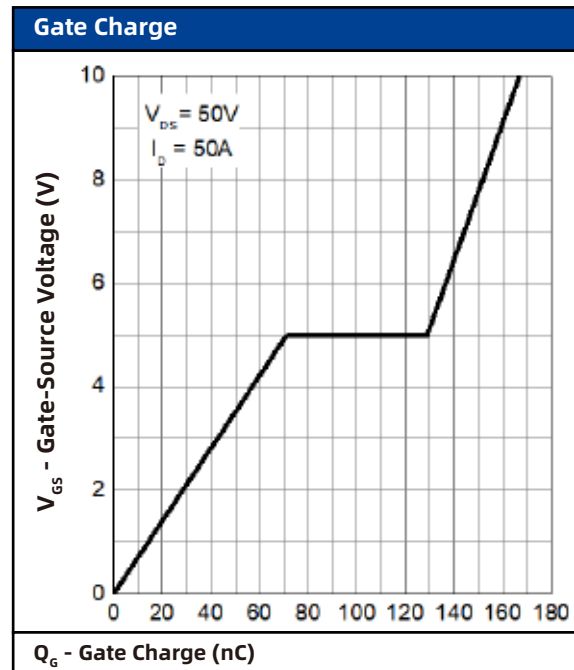
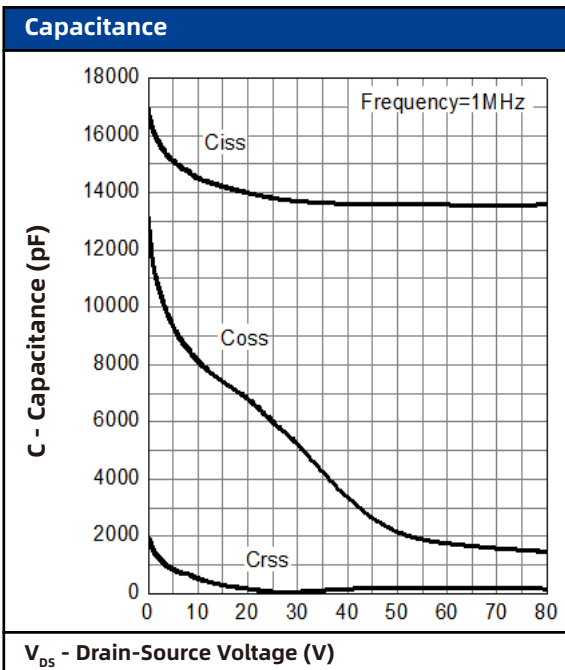
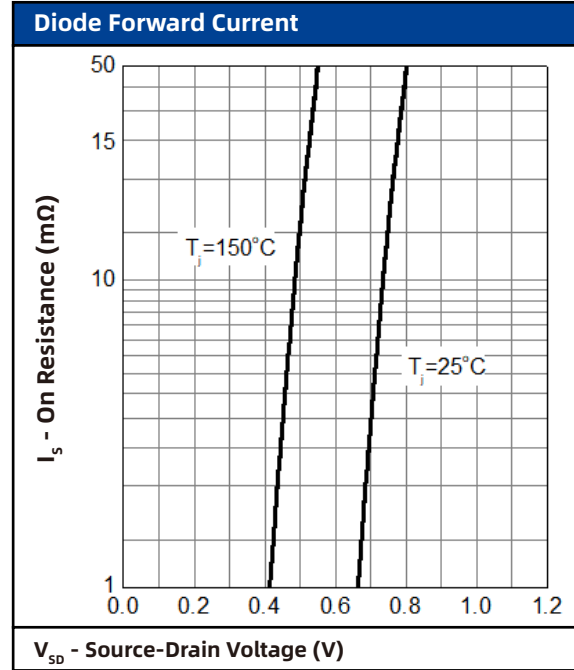
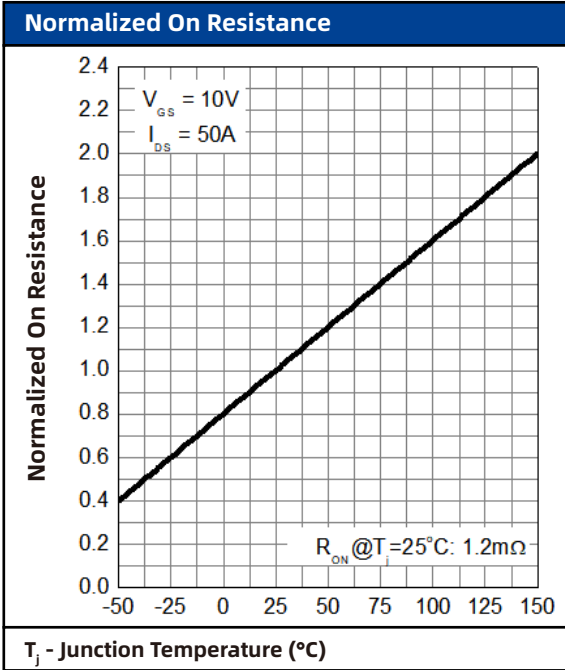

## 8. Package Dimensions

### TO-263-7L Package

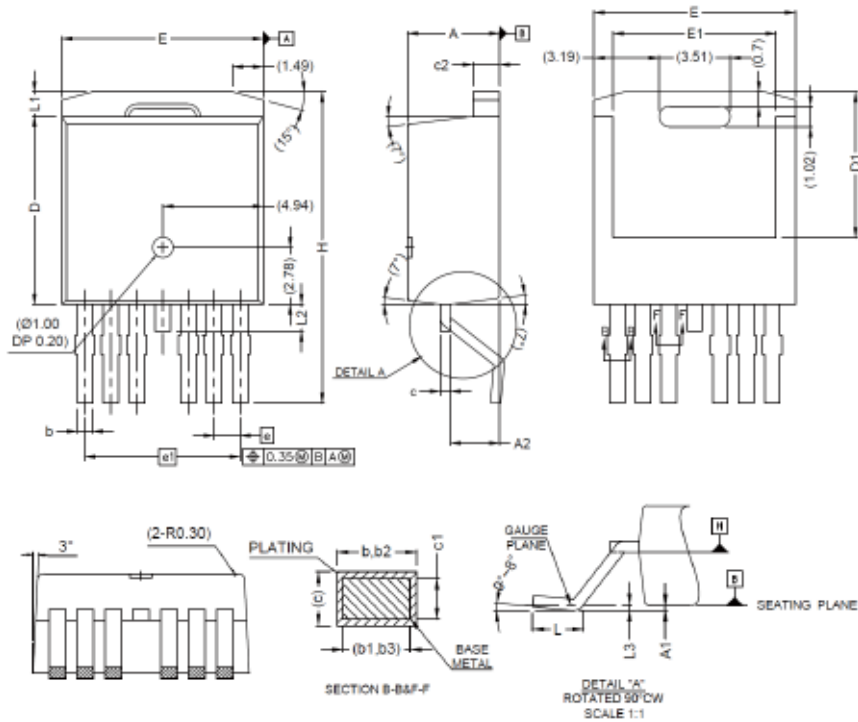

Symbol	Dimensions In Millimeters	
	Min	Max
A	4.30	4.70
A1	-	0.25
A2	2.20	2.60
b	0.65	0.85
b1	0.65	0.80
b2	0.80	1.00
b3	0.80	0.95
c	0.45	0.60
c1	0.45	0.55
c2	1.25	1.40
D	9.00	9.40
D1	6.86	7.42
E	9.68	10.08
E1	7.70	8.30
e	1.27 BSC	
e1	7.62 BSC	
L	1.78	2.79
L1	-	1.60
L2	-	1.78
L3	0.25BSD	
H	14.61	15.88