

## 30V N-Channel Enhancement Mode MOSFET

### 1. Product Information

#### 1.1 Features

- ◇ Surface-mounted package
- ◇ Low Thermal Resistance
- ◇ Advanced SGT cell design

#### 1.2 Applications

- ◇ Motor drivers
- ◇ DC-DC Converter

#### 1.3 Quick reference

- ◇  $BV \cong 30\text{ V}$
- ◇  $P_{\text{tot}} \cong 300\text{ W}$
- ◇  $I_D \cong 200\text{ A}$
- ◇  $R_{\text{DS(ON)}} \cong 0.50\text{ m}\Omega @ V_{\text{GS}} = 10\text{ V}$
- ◇  $R_{\text{DS(ON)}} \cong 0.80\text{ m}\Omega @ V_{\text{GS}} = 4.5\text{ V}$

### 2. Pin Description

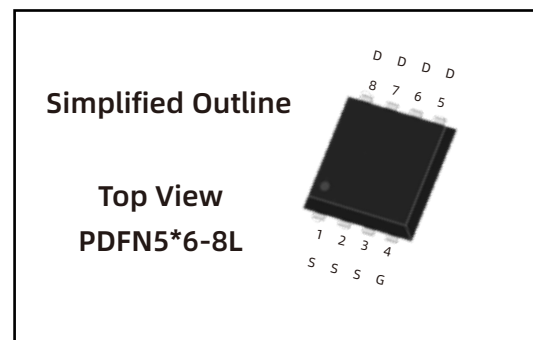

### 3. Marking Information

Product Name	Marking
LN004N030G	LN004N030G CYWWZZ XXXXXX

## 4.Limiting Values

Symbol	Parameter	Conditions	Min	Max	Unit
$V_{DS}$	Drain-Source Voltage	$T_C = 25\text{ }^\circ\text{C}$	-	30	V
$V_{GS}$	Gate-Source Voltage	$T_C = 25\text{ }^\circ\text{C}$	-	$\pm 20$	V
$I_D^*$	Drain Current ( DC )	$T_C = 25\text{ }^\circ\text{C}, V_{GS} = 10\text{ V}$	-	200	A
		$T_C = 100\text{ }^\circ\text{C}, V_{GS} = 10\text{ V}$	-	200	A
$I_{DM}^{*,**}$	Drain Current ( Pulsed )	$T_C = 25\text{ }^\circ\text{C}, V_{GS} = 10\text{ V}$	-	800	A
$P_{tot}$	Drain power dissipation	$T_C = 25\text{ }^\circ\text{C}$	-	300	W
$T_{stg}$	Storage Temperature		-55	175	$^\circ\text{C}$
$T_J$	Junction Temperature		-	175	$^\circ\text{C}$
$I_S$	Diode Forward Current	$T_C = 25\text{ }^\circ\text{C}$	-	200	A
$E_{AS}^*$	Single Pulsed Avalanche Energy	$V_{DD} = 30\text{ V}, L = 1.0\text{ mH}$	-	1300	mJ
$R_{\theta JA}^*$	Thermal Resistance- Junction to Ambient		-	54	$^\circ\text{C}/\text{W}$
$R_{\theta JC}$	Thermal Resistance- Junction to Case		-	0.5	

Notes :

- \* Surface Mounted on 1 in<sup>2</sup> pad area,  $t \leq 10\text{ sec}$
- \*\* Pulse width  $\leq 300\text{ }\mu\text{s}$ , duty cycle  $\leq 2\%$
- \*\*\* limited by bonding wire

## 5.Ordering Code

Product Name	Package	Reel Size	Tape width	Quantity	Note
LN004N030G	PDFN5*6			5000	

Note: COMTECH defines " Green " as lead-free ( RoHS compliant ) and halogen free ( Br or Cl does not exceed 900 ppm by weight in homogeneous material and total of Br and Cl does not exceed 1500 ppm by weight);

## 6. Electrical Characteristics (TA=25 ° Unless Otherwise Noted )

Symbol	Parameter	Conditions	Min	Typ	Max	Unit
<b>Static Characteristics</b>						
$BV_{DSS}$	Drain-Source Breakdown Voltage	$V_{GS} = 0\text{ V}, I_{DS} = 250\ \mu\text{A}$	30	-	-	V
$V_{GS(th)}$	Gate Threshold Voltage	$V_{DS} = V_{GS}, I_{DS} = 250\ \mu\text{A}$	1	-	2	V
$I_{DSS}$	Drain Leakage Current	$V_{DS} = 24\text{ V}, V_{GS} = 0\text{ V}$	-	-	1	$\mu\text{A}$
$I_{GSS}$	Gate Leakage Current	$V_{GS} = \pm 20\text{ V}, V_{DS} = 0\text{ V}$	-	-	$\pm 100$	nA
$R_{DS(on)}^a$	On-State Resistance	$V_{GS} = 10\text{ V}, I_{DS} = 50\text{ A}$	-	0.45	0.50	m $\Omega$
		$V_{GS} = 4.5\text{ V}, I_{DS} = 30\text{ A}$	-	0.66	0.80	
<b>Diode Characteristics</b>						
$V_{SD}^a$	Diode Forward Voltage	$I_{SD} = 50\text{ A}, V_{GS} = 0\text{ V}$	-	-	1.3	V
$t_{rr}$	Reverse Recovery Time	$I_{SD} = 40\text{ A}, V_{GS} = 0\text{ V}$	-	55	-	nS
$Q_{rr}$	Reverse Recovery Charge	$di_{SD}/dt = 100\text{ A}/\mu\text{s}$	-	48	-	nC
<b>Dynamic Characteristics<sup>b</sup></b>						
$C_{ISS}$	Input Capacitance	$V_{GS} = 0\text{ V}, V_{DS} = 15\text{ V}$ Frequency = 1 MHz	-	8282	-	pF
$C_{OSS}$	Output Capacitance		-	3205	-	
$C_{rSS}$	Reverse Transfer Capacitance		-	204	-	
$t_d(on)$	Turn-on Delay Time	$V_{DS} = 15\text{ V}, V_{GEN} = 10\text{ V},$ $R_G = 3.9\ \Omega, R_L = 0.3\ \Omega,$ $I_{DS} = 30\text{ A}$	-	11	-	nS
$t_r$	Turn-on Rise Time		-	140	-	
$t_d(off)$	Turn-off Delay Time		-	164	-	
$t_f$	Turn-off Fall Time		-	131	-	
<b>Gate Charge Characteristics<sup>b</sup></b>						
$Q_g$	Total Gate Charge	$V_{DS} = 15\text{ V}, V_{GS} = 10\text{ V},$ $I_{DS} = 50\text{ A}$	-	142		nC
$Q_{gs}$	Gate-Source Charge		-	27		
$Q_{gd}$	Gate-Drain Charge		-	20		

Notes :

a : Pulse test ; pulse width  $\leq 300\ \mu\text{s}$ , duty cycle  $\leq 2\%$

b : Guaranteed by design, not subject to production testing

## 7. Typical Characteristics

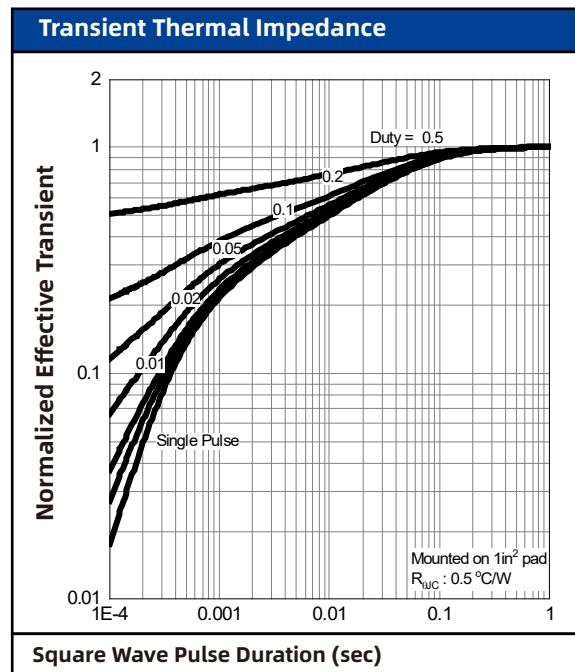
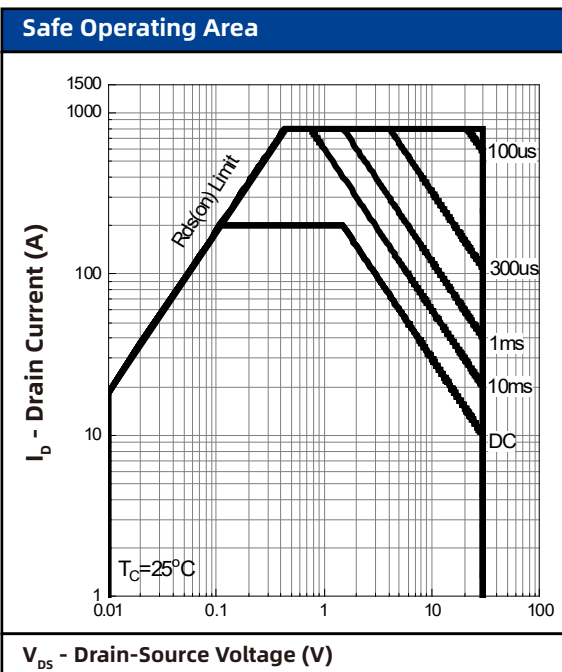
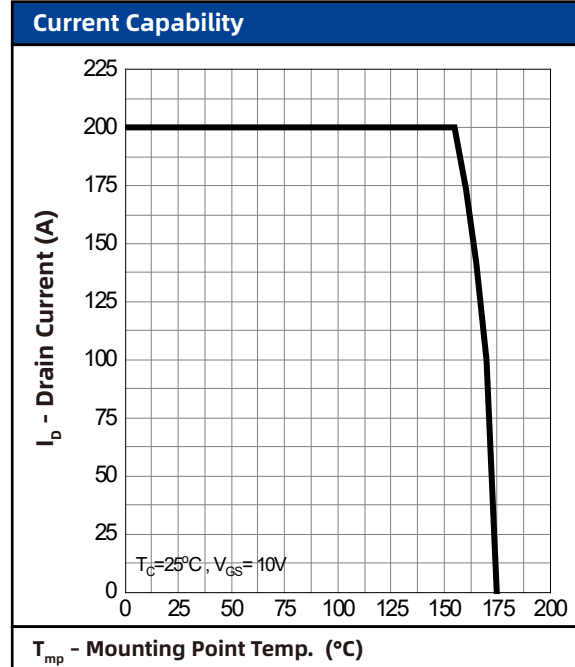
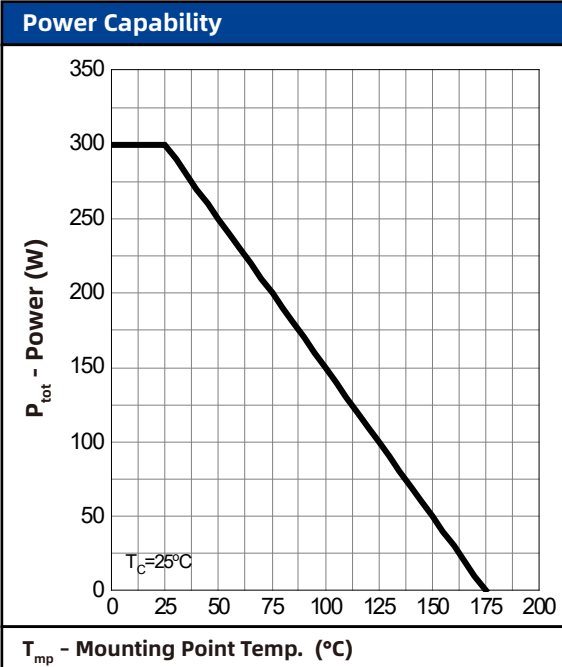

## 7. Typical Characteristics (cont.)

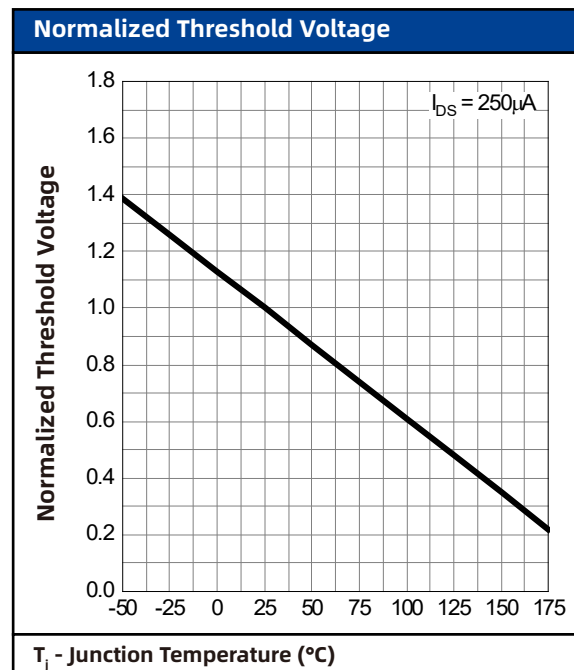
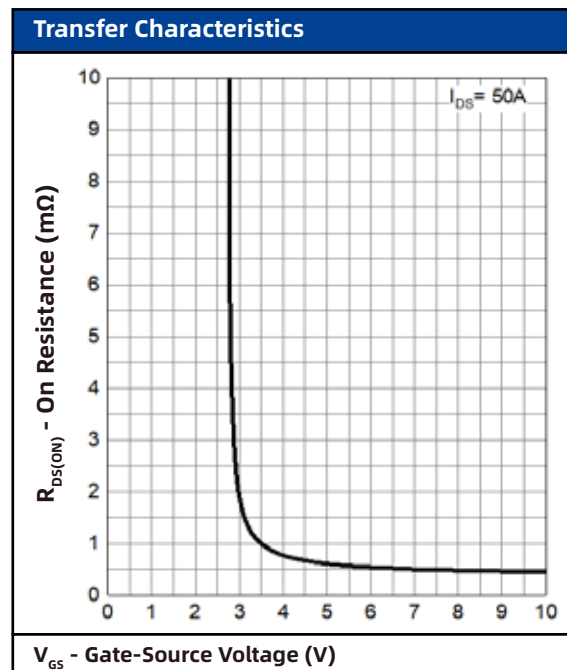
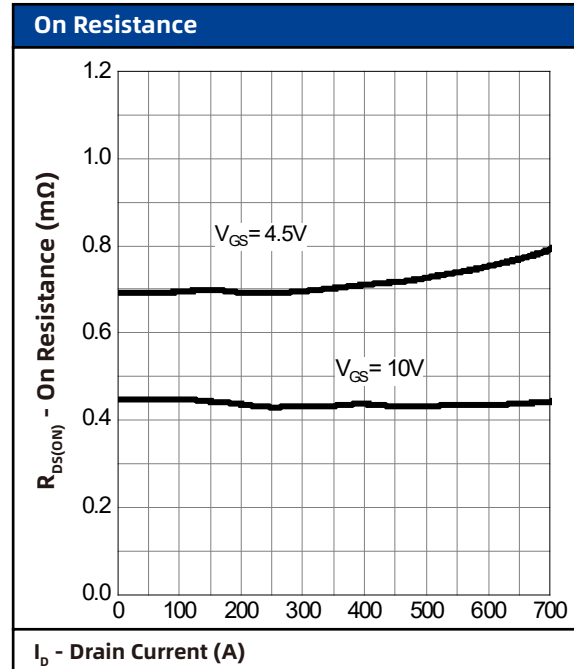
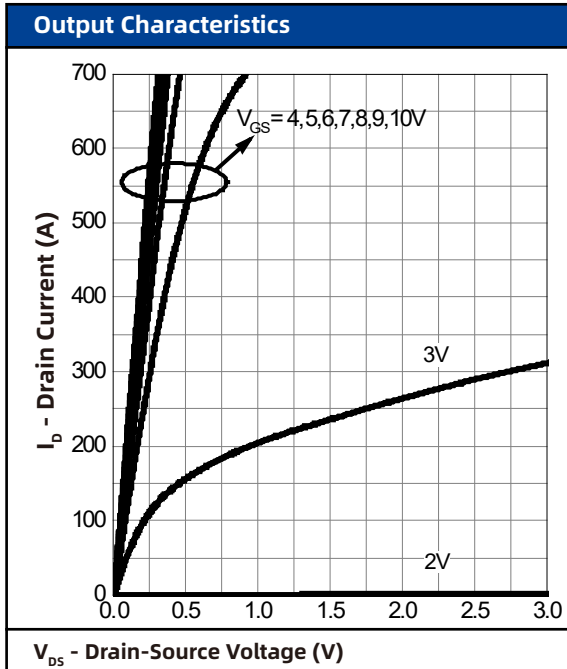

## 7. Typical Characteristics (cont.)

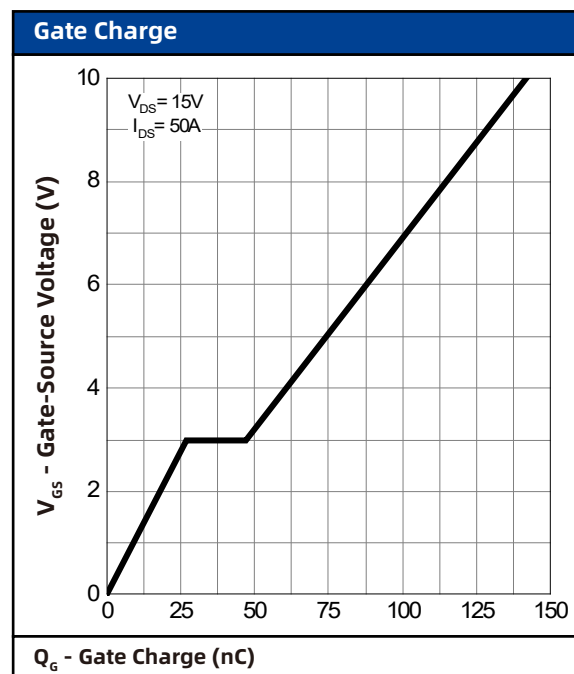
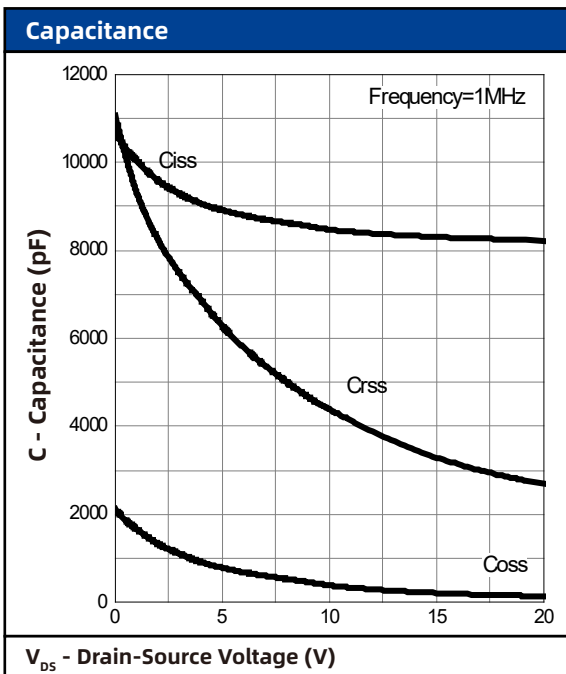
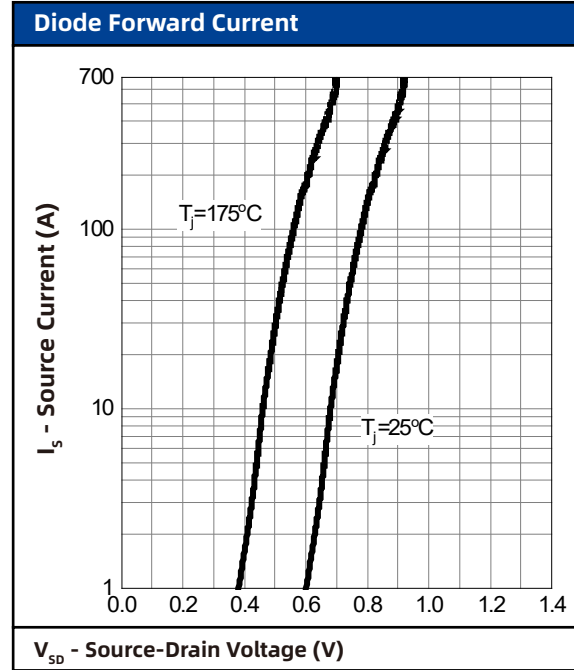
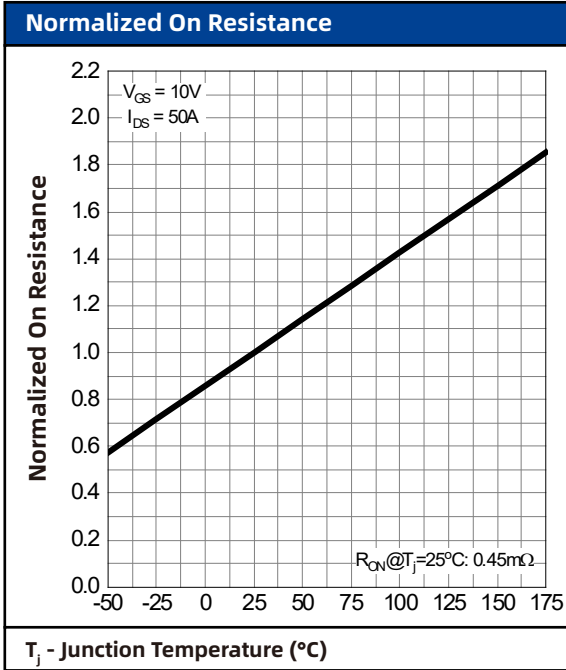

## 8. Package Dimensions

### PDFN5\*6-8L Package

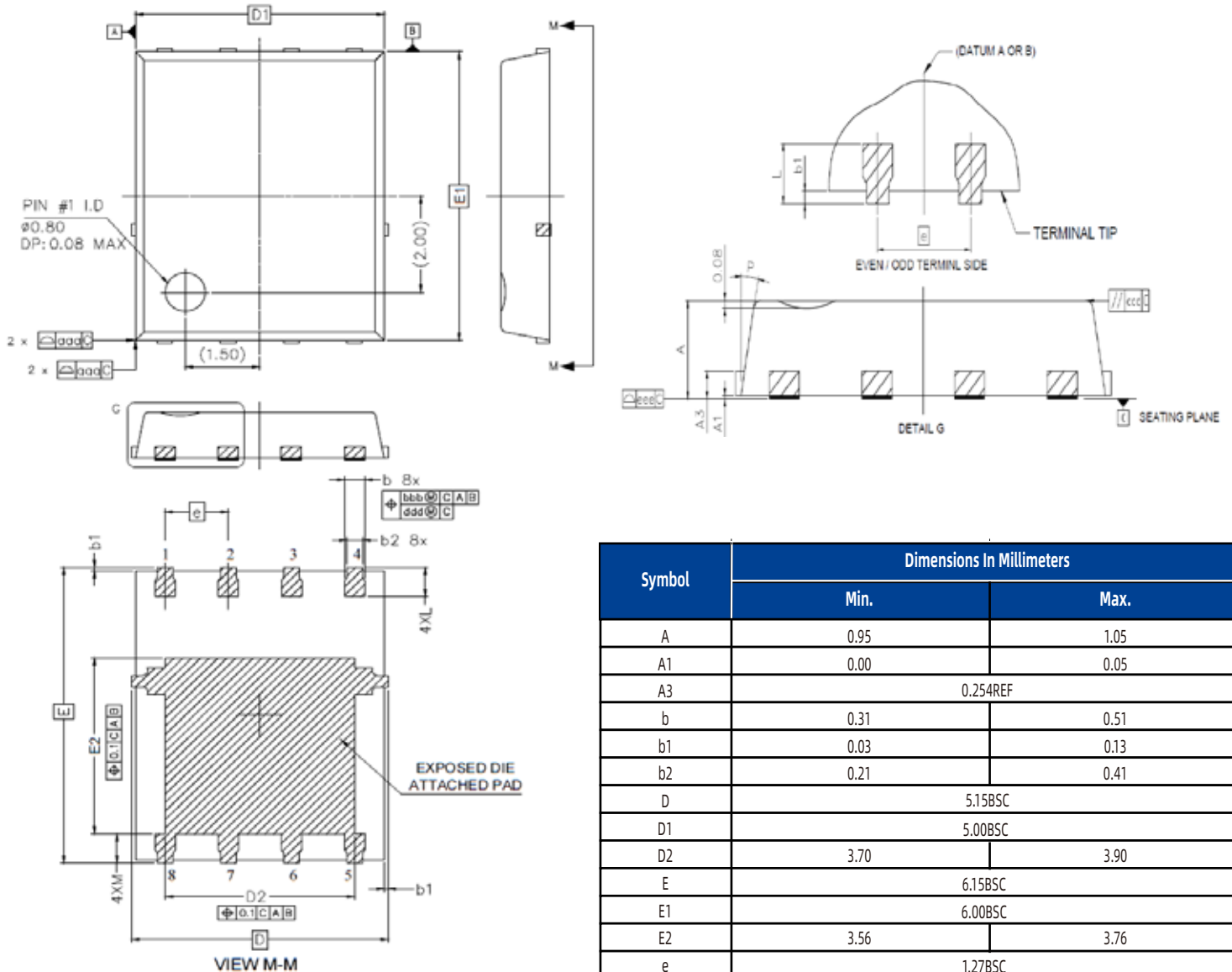

Symbol	Dimensions In Millimeters	
	Min.	Max.
A	0.95	1.05
A1	0.00	0.05
A3	0.254REF	
b	0.31	0.51
b1	0.03	0.13
b2	0.21	0.41
D	5.15BSC	
D1	5.00BSC	
D2	3.70	3.90
E	6.15BSC	
E1	6.00BSC	
E2	3.56	3.76
e	1.27BSC	
L	0.51	0.71
M	0.51	0.71
p	10°	12°
aaa	0.10	
bbb	0.10	
ccc	0.10	
ddd	0.05	
eee	0.08	