

## 30V N-Channel Enhancement Mode MOSFET

### 1. Product Information

#### 1.1 Features

- ◇ Surface-mounted package
- ◇ Low Thermal Resistance
- ◇ Advanced SGT cell design

#### 1.2 Applications

- ◇ Motor drivers
- ◇ DC - DC Converter

#### 1.3 Quick reference

- ◇  $BV \cong 30\text{ V}$
- ◇  $P_{\text{tot}} \cong 375\text{ W}$
- ◇  $I_D \cong 300\text{ A}$
- ◇  $R_{\text{DS(ON)}} \cong 0.4\text{m}\Omega @ V_{\text{GS}} = 10\text{ V}$
- ◇  $R_{\text{DS(ON)}} \cong 0.7\text{m}\Omega @ V_{\text{GS}} = 4.5\text{ V}$

### 2. Pin Description

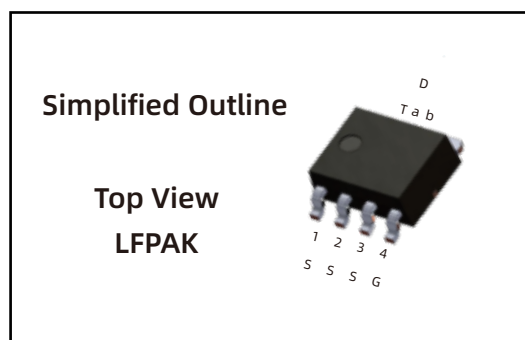
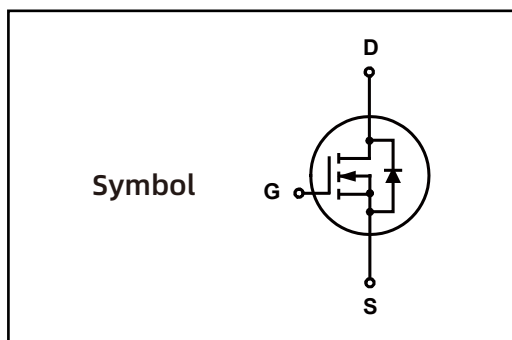

### 3. Marking Information

Product Name	Marking
LN004N030LF	LN004N030LF CYWWZZ XXXXXX

## 4.Limiting Values

Symbol	Parameter	Conditions	Min	Max	Unit
$V_{DS}$	Drain-Source Voltage	$T_C = 25\text{ }^\circ\text{C}$	-	30	V
$V_{GS}$	Gate-Source Voltage	$T_C = 25\text{ }^\circ\text{C}$	-	$\pm 20$	V
$I_D^*, ***$	Drain Current ( DC )	$T_C = 25\text{ }^\circ\text{C}, V_{GS} = 10\text{ V}$	-	300	A
		$T_C = 100\text{ }^\circ\text{C}, V_{GS} = 10\text{ V}$	-	300	A
$I_{DM}^*, **$	Drain Current ( Pulsed )	$T_C = 25\text{ }^\circ\text{C}, V_{GS} = 10\text{ V}$	-	1200	A
$P_{tot}^*$	Total power dissipation	$T_C = 25\text{ }^\circ\text{C}$	-	375	W
$T_{stg}$	Storage Temperature		-55	175	$^\circ\text{C}$
$T_J$	Junction Temperature		-	175	$^\circ\text{C}$
$I_S$	Diode Forward Current	$T_C = 25\text{ }^\circ\text{C}$	-	300	A
$E_{AS}^*$	Single Pulsed Avalanche Energy	$V_{DD} = 30\text{ V}, L = 1\text{ mH}$	-	1250	mJ
$R_{\theta JA}^*$	Thermal Resistance- Junction to Ambient		-	60	$^\circ\text{C}/\text{W}$
$R_{\theta JC}^*$	Thermal Resistance- Junction to Case		-	0.4	

Notes :

- \* Surface Mounted on 1 in<sup>2</sup> pad area,  $t \leq 10$  sec
- \*\* Pulse width  $\leq 300\text{ }\mu\text{s}$ , duty cycle  $\leq 2\%$
- \*\*\* Limited by bonding wire

## 5.Ordering Code

Product Name	Package	Reel Size	Tape width	Quantity	Note
LN004N030LF	LFPAK5*6			5000	

Note: COMTECH defines " Green " as lead-free ( RoHS compliant ) and halogen free ( Br or Cl does not exceed 900 ppm by weight in homogeneous material and total of Br and Cl does not exceed 1500 ppm by weight; Follow IEC 61249-2-21 and IPC / JEDEC J-STD-020C )

## 6. Electrical Characteristics (TA=25 ° Unless Otherwise Noted )

Symbol	Parameter	Conditions	Min	Typ	Max	Unit
<b>Static Characteristics</b>						
$BV_{DSS}$	Drain-Source Breakdown Voltage	$V_{GS} = 0 V, I_{DS} = 250 \mu A$	30	-	-	V
$V_{GS(th)}$	Gate Threshold Voltage	$V_{DS} = V_{GS}, I_{DS} = 250 \mu A$	1	-	2	V
$I_{DSS}$	Drain Leakage Current	$V_{DS} = 24 V, V_{GS} = 0 V$	-	-	1	$\mu A$
$I_{GSS}$	Gate Leakage Current	$V_{GS} = 0 V, V_{GS} = \pm 20 V$	-	-	$\pm 100$	nA
$R_{DS(on)}^a$	On-State Resistance	$V_{GS} = 10 V, I_{DS} = 50 A$	-	0.35	0.4	m $\Omega$
		$V_{GS} = 4.5 V, I_{DS} = 30 A$	-	0.6	0.7	
<b>Diode Characteristics</b>						
$V_{SD}^a$	Diode Forward Voltage	$I_{SD} = 50 A, V_{GS} = 0 V$	-	-	1.3	V
$t_{rr}$	Reverse Recovery Time	$I_{DS} = 50 A, V_{GS} = 0 V$	-	53	-	nS
$Q_{rr}$	Reverse Recovery Charge	$di_{SD}/dt = 100 A/\mu s$	-	48	-	nC
<b>Dynamic Characteristics<sup>b</sup></b>						
$C_{ISS}$	Input Capacitance	$V_{GS} = 0 V, V_{DS} = 15 V$ Frequency = 1 MHz	-	8366	-	pF
$C_{OSS}$	Output Capacitance		-	4056	-	
$C_{rSS}$	Reverse Transfer Capacitance		-	118	-	
$t_d(on)$	Turn-on Delay Time	$V_{DS} = 15 V, V_{GEN} = 10 V,$ $R_G = 3.9 \Omega, R_L = 0.3 \Omega,$ $I_{DS} = 50 A$	-	13	-	nS
$t_r$	Turn-on Rise Time		-	141	-	
$t_d(off)$	Turn-off Delay Time		-	164	-	
$t_f$	Turn-off Fall Time		-	107	-	
<b>Gate Charge Characteristics<sup>b</sup></b>						
$Q_g$	Total Gate Charge	$V_{DS} = 15 V, V_{GS} = 10 V,$ $I_{DS} = 50 A$	-	141	-	nC
$Q_{gs}$	Gate-Source Charge		-	26	-	
$Q_{gd}$	Gate-Drain Charge		-	20	-	

Notes :

a : Pulse test ; pulse width  $\leq 300 \mu s$ , duty cycle  $\leq 2\%$

b : Guaranteed by design, not subject to production testing

## 7. Typical Characteristics

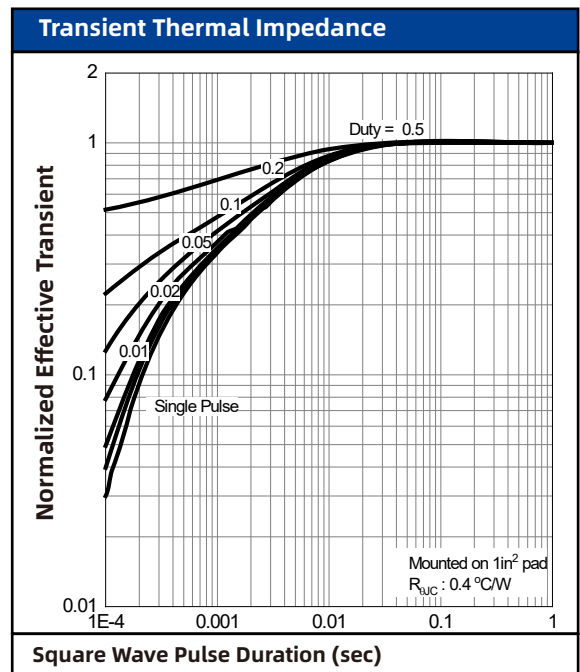
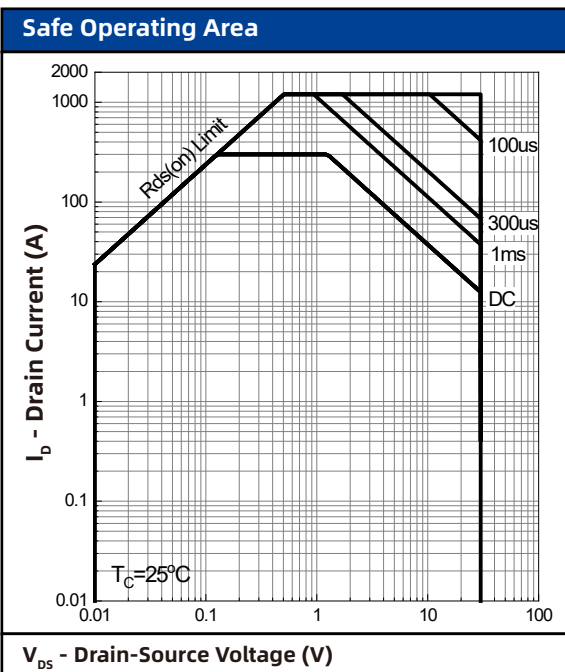
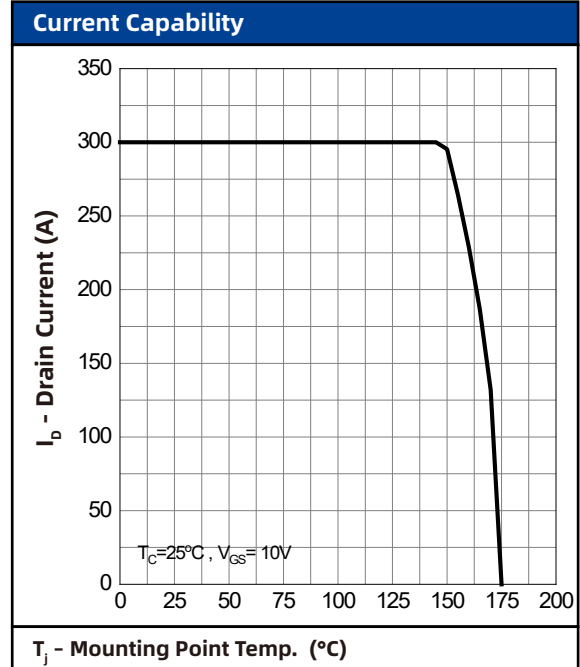
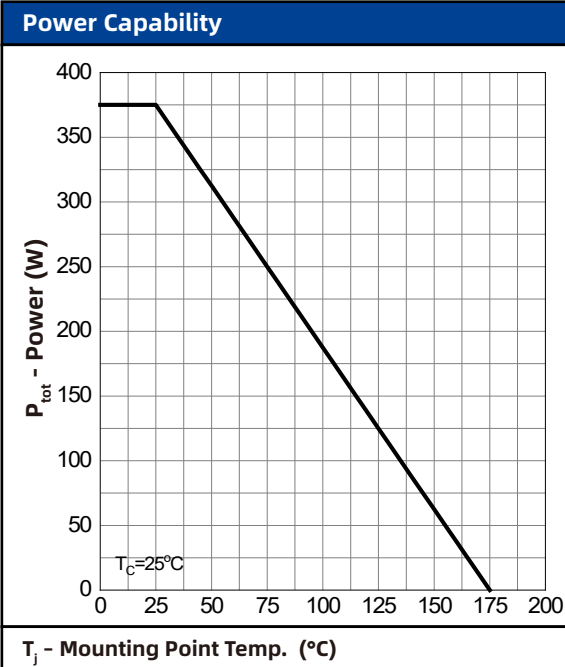

## 7. Typical Characteristics (cont.)

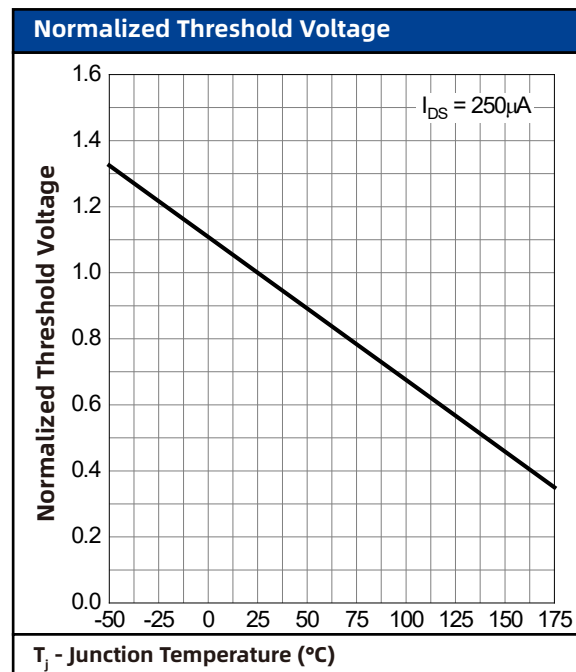
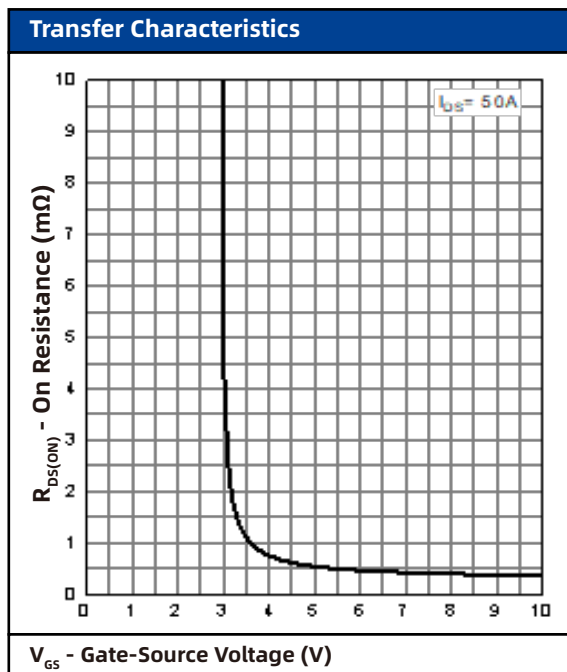
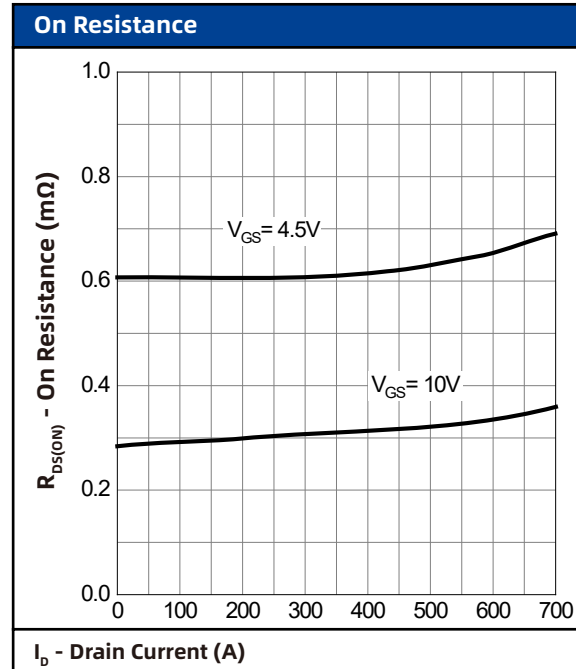
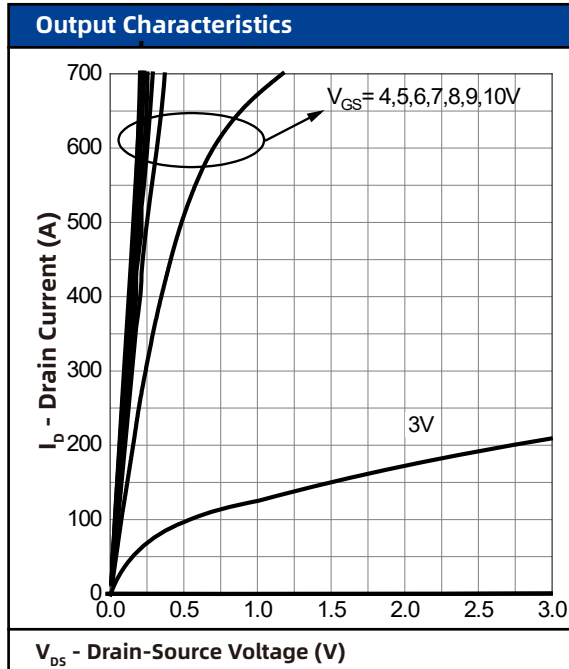

## 7. Typical Characteristics (cont.)

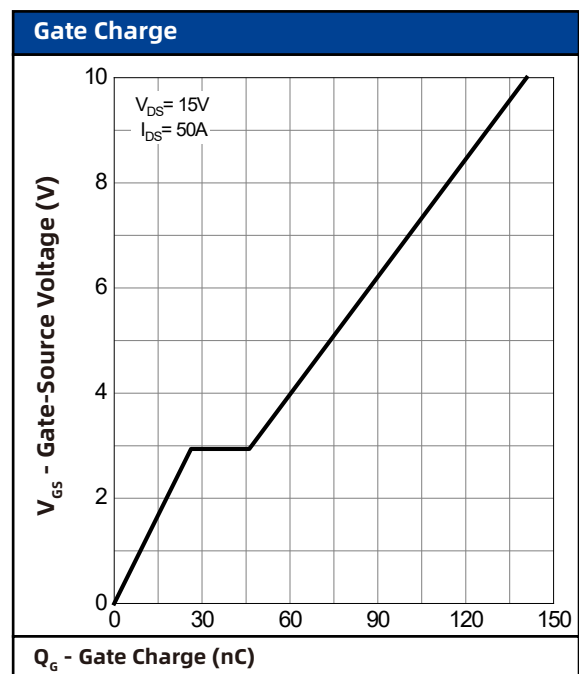
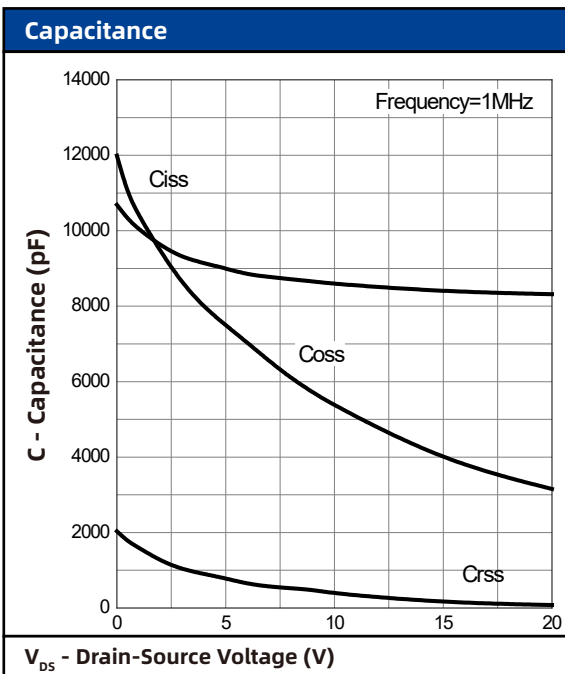
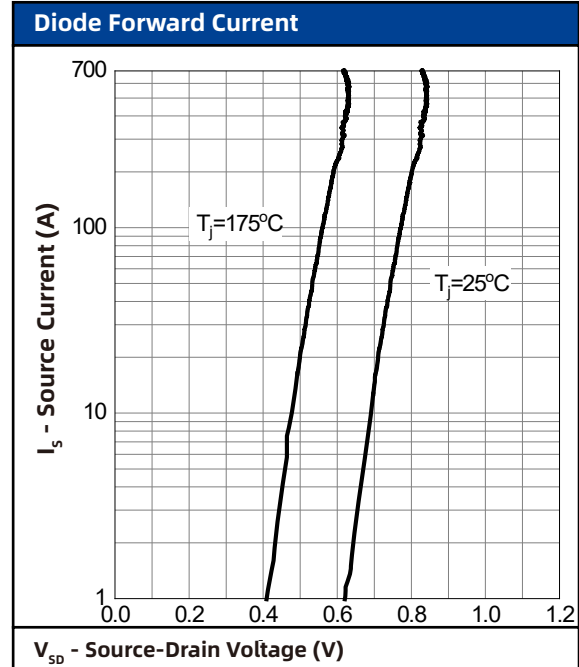
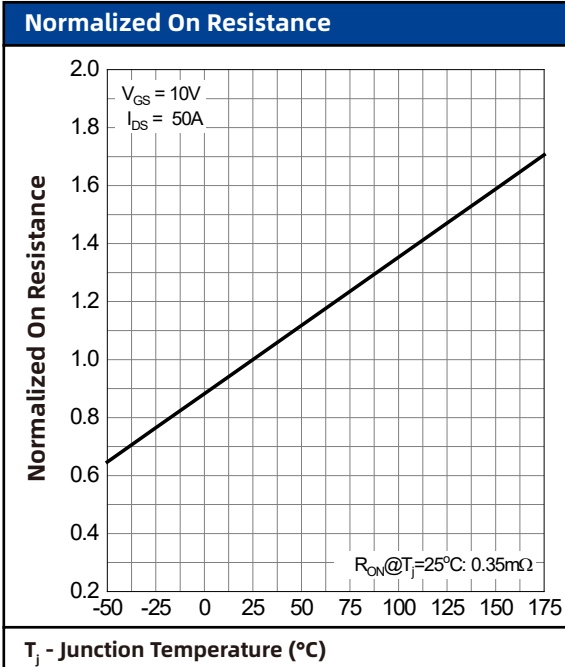

## 8. Package Dimensions

### LFPAK5\*6 Package

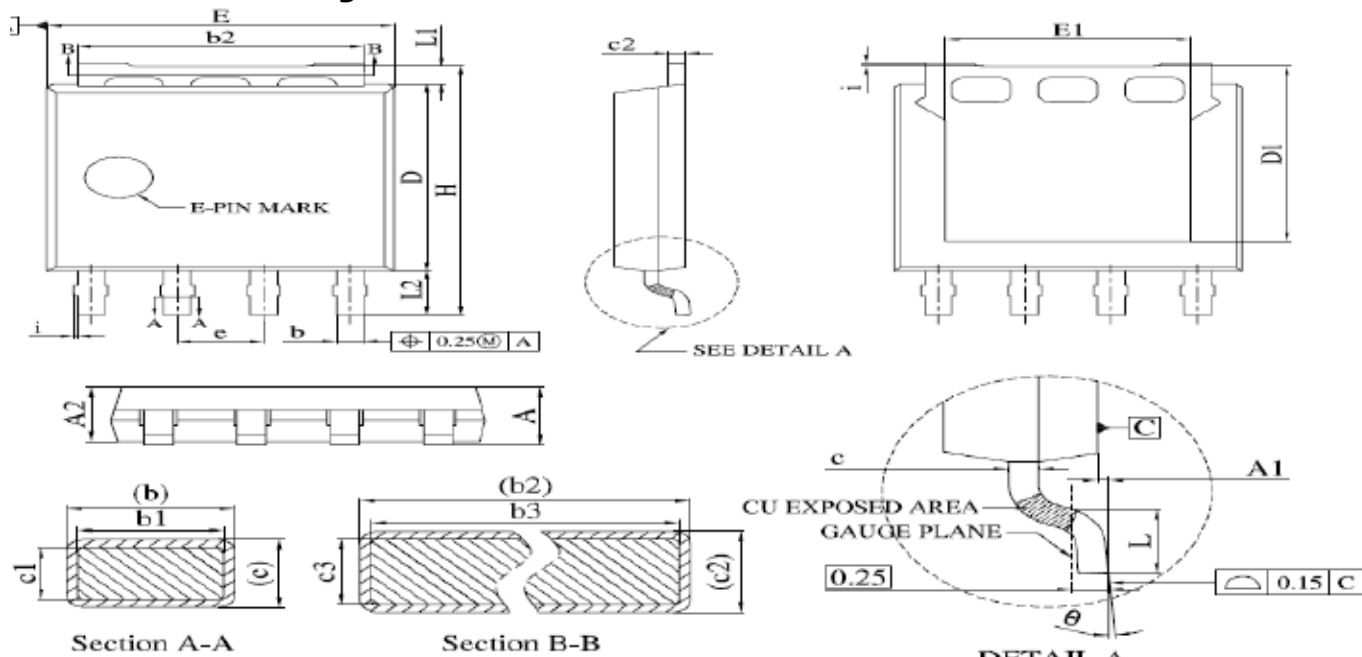

Symbol	Dimensions In Millimeters	
	Min.	Max.
A	1.00	1.30
A1	0.00	0.15
A2	0.98	1.12
b	0.35	0.50
b1	0.32	0.46
b2	4.02	4.41
b3	4.00	4.37
c	0.19	0.25
c1	0.17	0.23
c2	0.24	0.30
c3	0.22	0.28
D	4.45	4.70
D1	-	4.45
E	4.95	5.30
E1	3.50°	3.70
e	1.27BSC	
H	5.95	6.25
i	-	0.25
L	0.40	0.85
L1	0.27	0.57
L2	0.80	1.30
θ	0°	8°