

60V N-Channel Enhancement Mode MOSFET

1. Product Information

1.1 Features

- ◇ Advanced SGT cell design
- ◇ Low Gate Charge
- ◇ Low On-Resistance
- ◇ RoHS and Halogen-Free Compliant
- ◇ 100% ΔV_{DS} & UIS & Rg Tested

1.2 Applications

- ◇ DC-DC Converter
- ◇ Drones
- ◇ Motor drivers
- ◇ Light electric vehicles

1.3 Quick reference

- ◇ $BV \cong 60\text{ V}$
- ◇ $P_{\text{tot}} \cong 81\text{ W}$
- ◇ $I_D \cong 97\text{ A}$
- ◇ $R_{DS(ON)} \cong 6.5\text{ m}\Omega @ V_{GS} = 10\text{ V}$
- ◇ $R_{DS(ON)} \cong 8.9\text{ m}\Omega @ V_{GS} = 4.5\text{ V}$



2. Pin Description

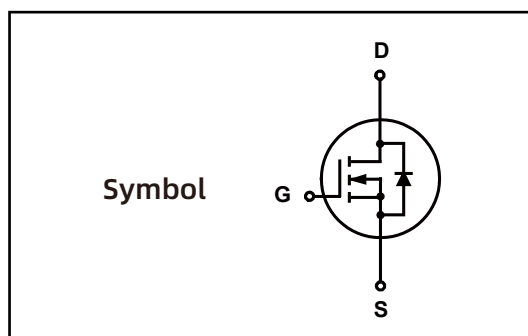

Simplified Outline

Top View
PDFN3.3*3.3



3.Limiting Values

| Symbol | Parameter | Conditions | Min | Max | Unit | Note |
|----------------------|--------------------------------|---|-----|----------|------------------|--------|
| V_{DS} | Drain-Source Voltage | $T_C = 25\text{ }^\circ\text{C}$ | - | 60 | V | - |
| V_{GS} | Gate-Source Voltage | $T_C = 25\text{ }^\circ\text{C}$ | - | ± 20 | V | - |
| I_D^* | Drain Current (DC) | $T_C = 25\text{ }^\circ\text{C}, V_{GS} = 10\text{ V}$ | - | 97 | A | Fig.2 |
| | | $T_C = 100\text{ }^\circ\text{C}, V_{GS} = 10\text{ V}$ | - | 61 | A | |
| $I_{DM}^{**},^{***}$ | Drain Current (Pulsed) | $T_C = 25\text{ }^\circ\text{C}, V_{GS} = 10\text{ V}$ | - | 167 | A | - |
| P_{tot} | Drain power dissipation | $T_C = 25\text{ }^\circ\text{C}$ | - | 81 | W | Fig.1 |
| | | $T_C = 100\text{ }^\circ\text{C}$ | - | 32 | W | |
| T_{stg} | Storage Temperature | | -55 | 150 | $^\circ\text{C}$ | - |
| T_J | Junction Temperature | | - | 150 | $^\circ\text{C}$ | - |
| I_S | Continuous-Source Current | $T_C = 25\text{ }^\circ\text{C}$ | - | 97 | A | - |
| E_{AS}^* | Single Pulsed Avalanche Energy | $V_{DD} = 60\text{ V}, L = 0.1\text{ mH}$ | - | 41 | mJ | Fig.19 |

4.Thermal Characteristics

| | | | | | |
|-------------------|---|---|------|--------------------|--------|
| $R_{\theta JA}^*$ | Thermal Resistance- Junction to Ambient | - | 36 | $^\circ\text{C/W}$ | Fig.16 |
| $R_{\theta JC}^*$ | Thermal Resistance- Junction to Case | - | 1.54 | | |

Notes :

* Surface Mounted on 1 in² pad area, $t \leq 10\text{ sec}$

** Pulse width $\leq 300\text{ }\mu\text{s}$, duty cycle $\leq 2\%$

*** limited by bonding wire

5.Marking Information

| Product Name | Package | Reel size | Tape width | Quantity | Note |
|--------------|-------------|-----------|------------|----------|------|
| LN065N060Q-L | PDFN3.3*3.3 | 330mm | 12mm | 5000 | |

Note: COMTECH defines " Green " as lead-free (RoHS compliant) and halogen free (Br or Cl does not exceed 900 ppm by weight in homogeneous material and total of Br and Cl does not exceed 1500 ppm by weight; Follow IEC 61249-2-21 and IPC / JEDEC J-STD-020C)

6. Electrical Characteristics ($T_A=25^\circ$ Unless Otherwise Noted)

| Symbol | Parameter | Conditions | Min | Typ | Max | Unit | Note |
|--|--------------------------------|--|-----|-------|-----------|---------------|--------|
| Static Characteristics | | | | | | | |
| BV_{DSS} | Drain-Source Breakdown Voltage | $V_{GS} = 0\text{ V}, I_{DS} = 250\ \mu\text{A}$ | 60 | - | - | V | |
| $V_{GS(th)}$ | Gate Threshold Voltage | $V_{DS} = V_{GS}, I_{DS} = 250\ \mu\text{A}$ | 1 | - | 3 | V | |
| I_{DSS} | Drain Leakage Current | $V_{DS} = 60\text{ V}, V_{GS} = 0\text{ V}$ | - | - | 1 | μA | |
| I_{GSS} | Gate Leakage Current | $V_{GS} = \pm 20\text{ V}, V_{DS} = 0\text{ V}$ | - | - | ± 100 | nA | |
| $R_{DS(on)}^a$ | On-State Resistance | $V_{GS} = 10\text{ V}, I_{DS} = 10\text{ A}$ | - | 6.3 | 6.5 | m Ω | Fig.8 |
| | | $V_{GS} = 4.5\text{ V}, I_{DS} = 10\text{ A}$ | - | 8.8 | 8.9 | | |
| Diode Characteristics | | | | | | | |
| V_{SD}^a | Diode Forward Voltage | $I_{SD} = 10\text{ A}, V_{GS} = 0\text{ V}$ | - | - | 1.3 | V | Fig.7 |
| t_{rr} | Reverse Recovery Time | $I_{DS} = 10\text{ A}, V_{GS} = 0\text{ V}$ $dI_{SD}/dt = 100\text{ A}/\mu\text{s}$ | - | 24 | - | nS | Fig.20 |
| Q_{rr} | Reverse Recovery Charge | | - | 41 | - | nC | |
| Dynamic Characteristics^b | | | | | | | |
| C_{ISS} | Input Capacitance | $V_{GS} = 0\text{ V}, V_{DS} = 30\text{ V}$ Frequency = 1 MHz | - | 1553 | - | pF | Fig.10 |
| C_{OSS} | Output Capacitance | | - | 539 | - | | |
| C_{rSS} | Reverse Transfer Capacitance | | - | 27 | - | | |
| R_G | Gate Resistance | F= 1 MHz | - | 4.2 | - | Ω | |
| $t_d(on)$ | Turn-on Delay Time | $V_{DS} = 30\text{ V}, V_{GS} = 10\text{ V},$ $R_G=2.7\ \Omega, R_L = 20\ \mu\text{H},$ $I_{DS} = 10\text{ A}$ | - | 18 | - | nS | Fig.18 |
| t_r | Turn-on Rise Time | | - | 57 | - | | |
| $t_d(off)$ | Turn-off Delay Time | | - | 32 | - | | |
| t_f | Turn-off Fall Time | | - | 11 | - | | |
| dv/dt | Peak Diode Recovery | | - | 0.425 | - | | |
| di/dt | Peak Diode Recovery | - | 393 | - | A/us | | |
| Gate Charge Characteristics^b | | | | | | | |
| Q_g | Total Gate Charge | $V_{DS} = 30\text{ V}, V_{GS} = 10\text{ V},$ $I_{DS} = 10\text{ A}$ | - | 29 | - | nC | Fig.9 |
| Q_{gs} | Gate-Source Charge | | - | 3 | - | | |
| Q_{gd} | Gate-Drain Charge | | - | 18 | - | | |
| $V_{plateau}$ | Gate plateau voltage | | - | 2.4 | - | | |

Notes :

a : Pulse test ; pulse width $\leq 300\ \mu\text{s}$, duty cycle $\leq 2\%$

b : Guaranteed by design, not subject to production testing

7. Typical Characteristics

Fig.1 Power Capability

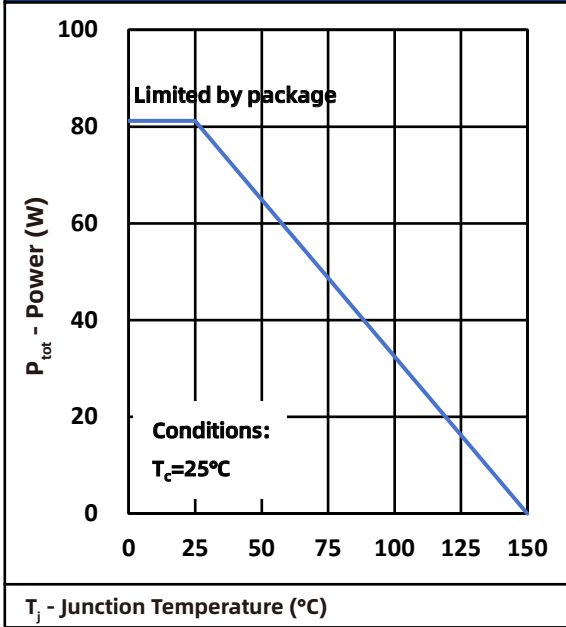

Fig.2 Current Capability

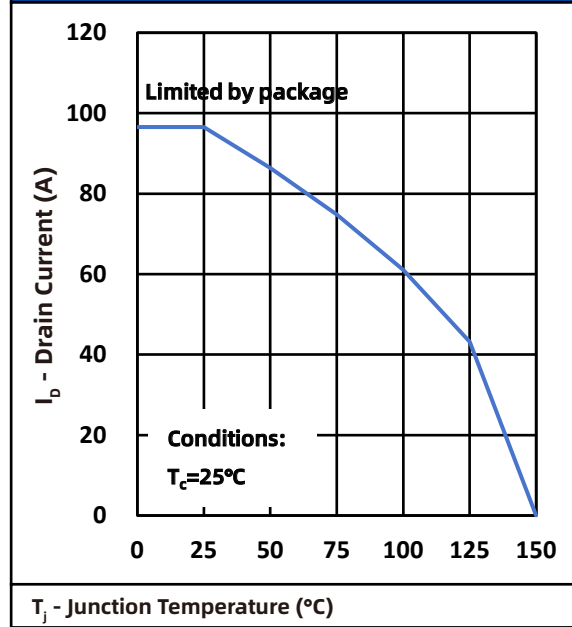

Fig.3 Output Characteristics@ $T_j = -55^\circ\text{C}$

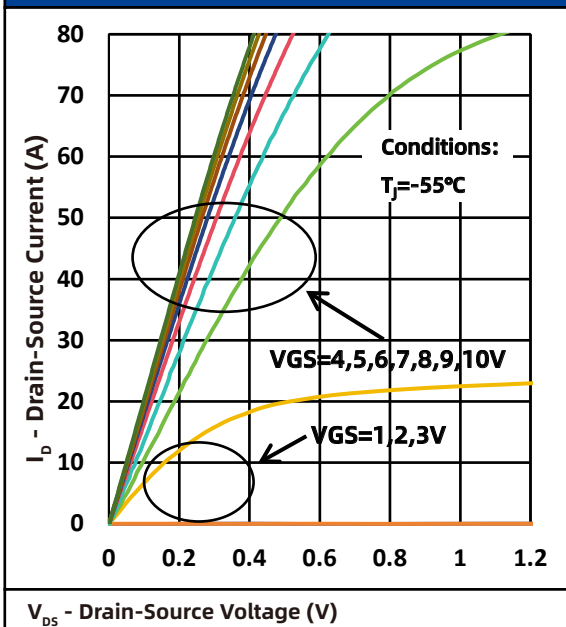
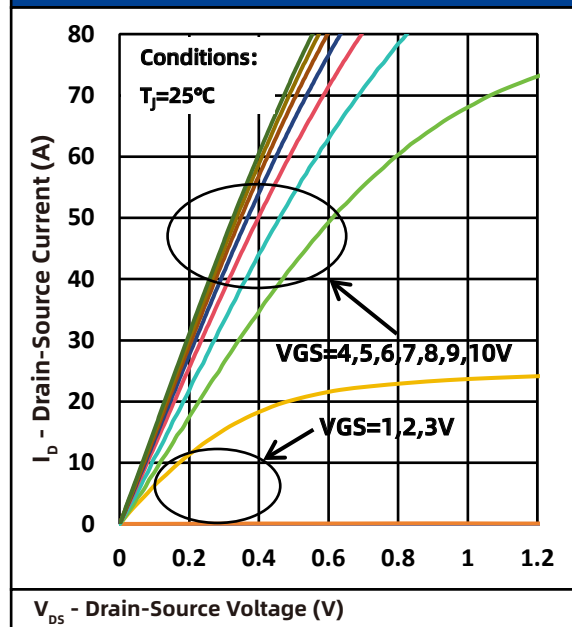

Fig.4 Output Characteristics@ $T_j = 25^\circ\text{C}$



7. Typical Characteristics

Fig.5 Output Characteristics@Tj 150°C

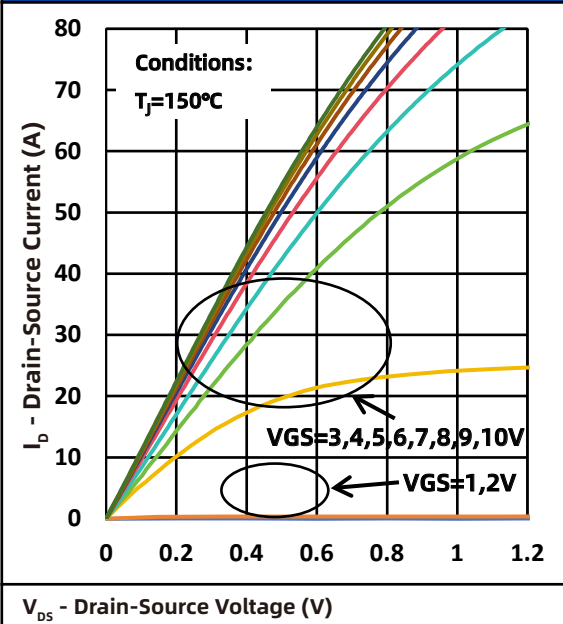

Fig.6 Transfer Characteristics vs Temp

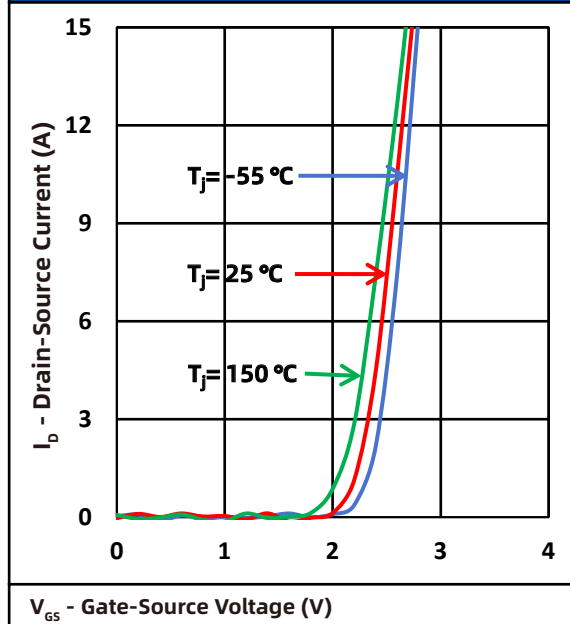

Fig.7 Body Diode Characteristics

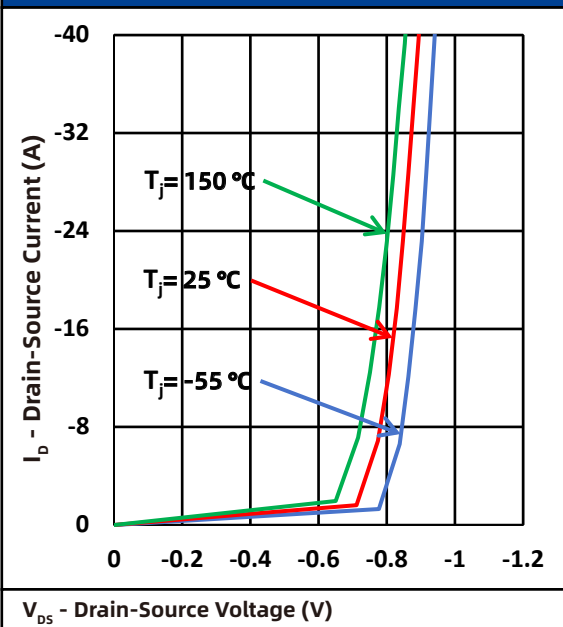
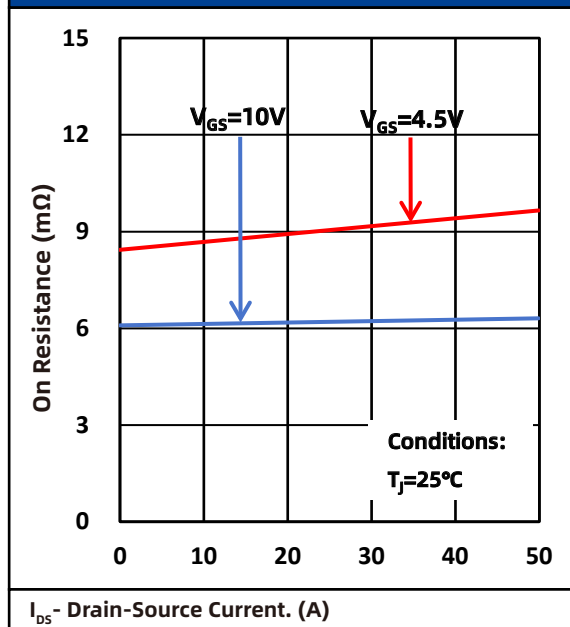
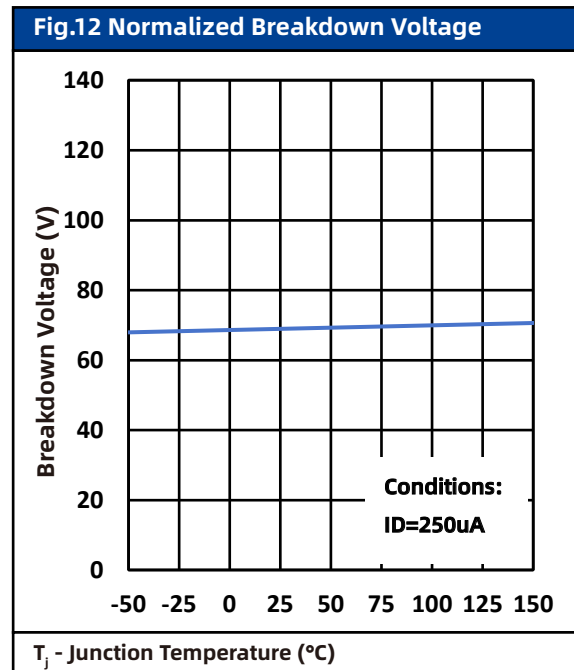
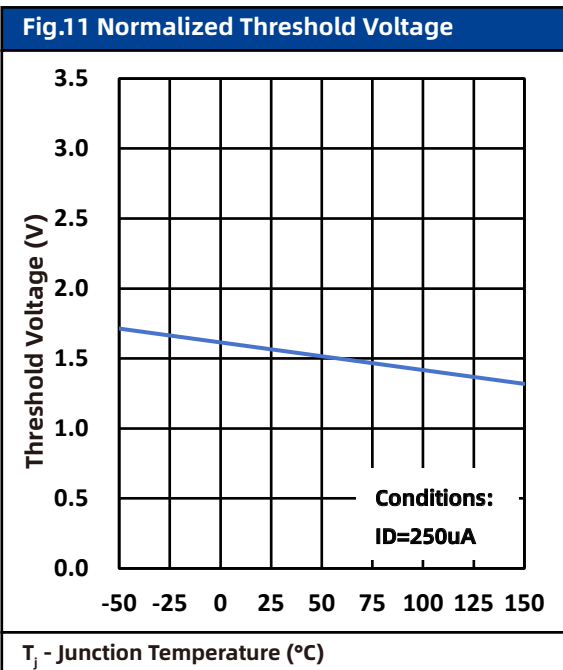
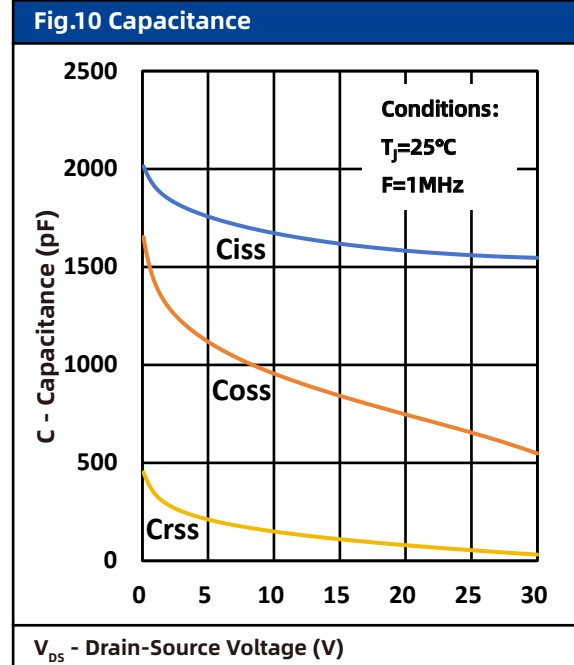
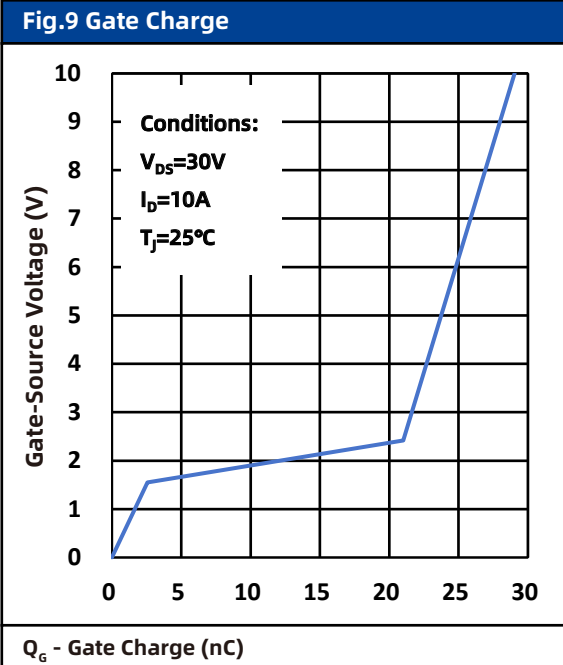

Fig.8 Drain-Source On Resistance



7. Typical Characteristics



7. Typical Characteristics

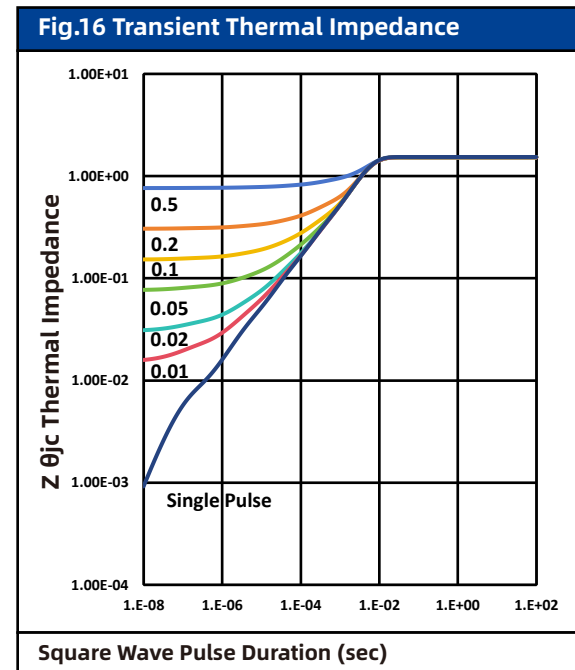
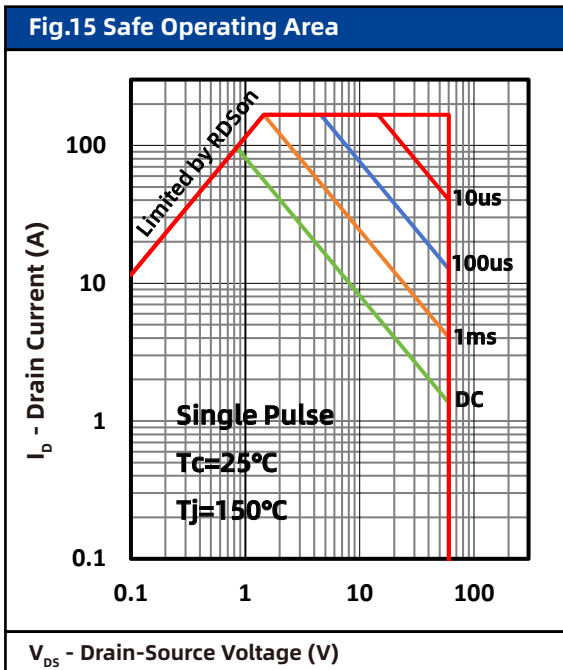
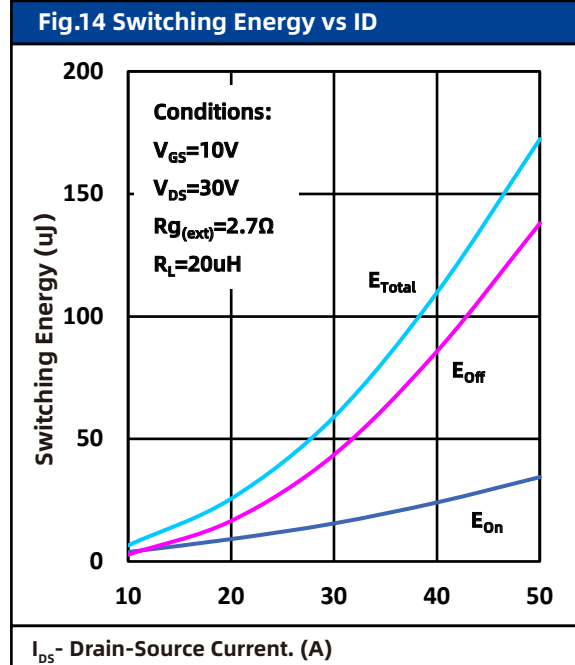
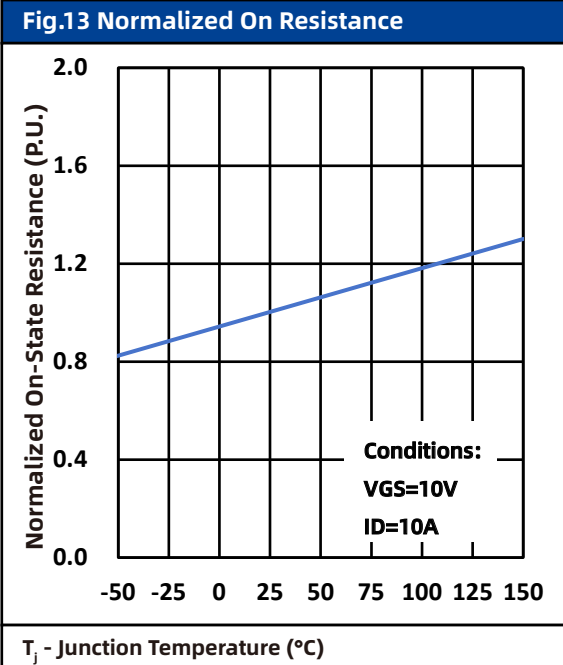

7. Typical Characteristics

Fig.17 Gate Charge Test Circuit & Waveform

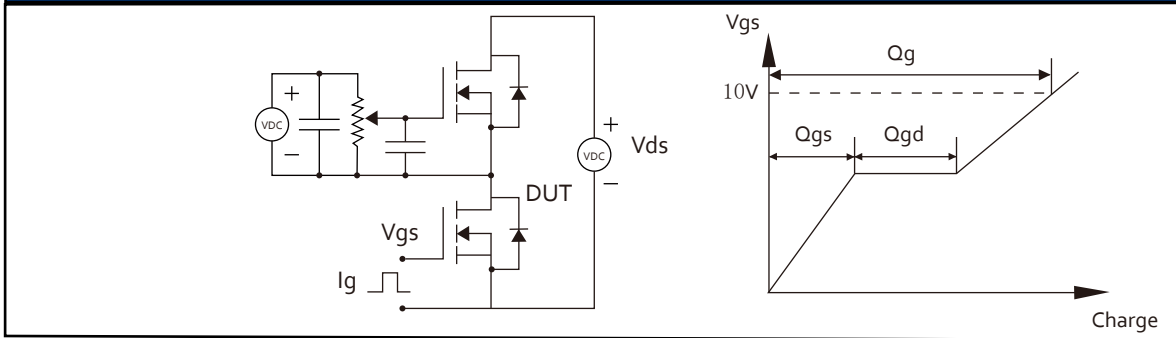

Fig.18 Resistive Switching Test Circuit & Waveforms

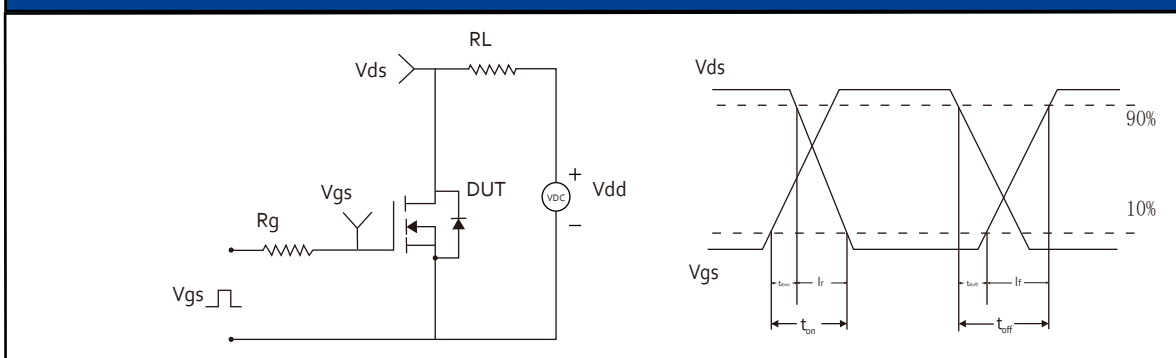

Fig.19 Unclamped Inductive Switching (UIS) Test Circuit & Waveforms

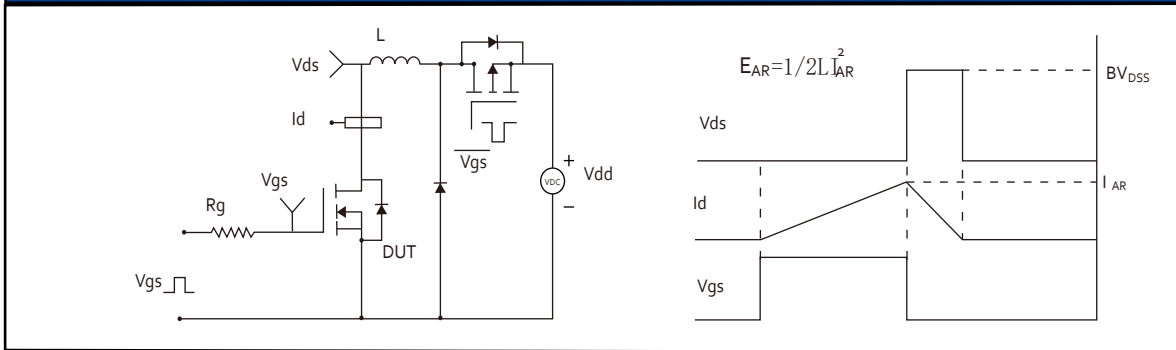
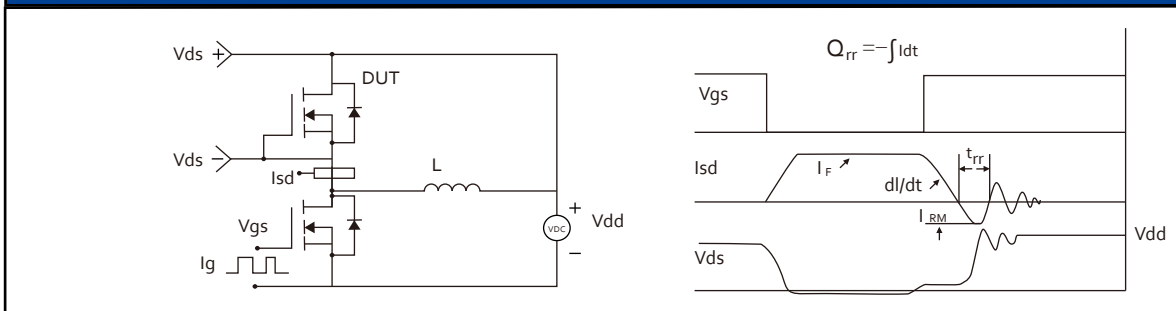
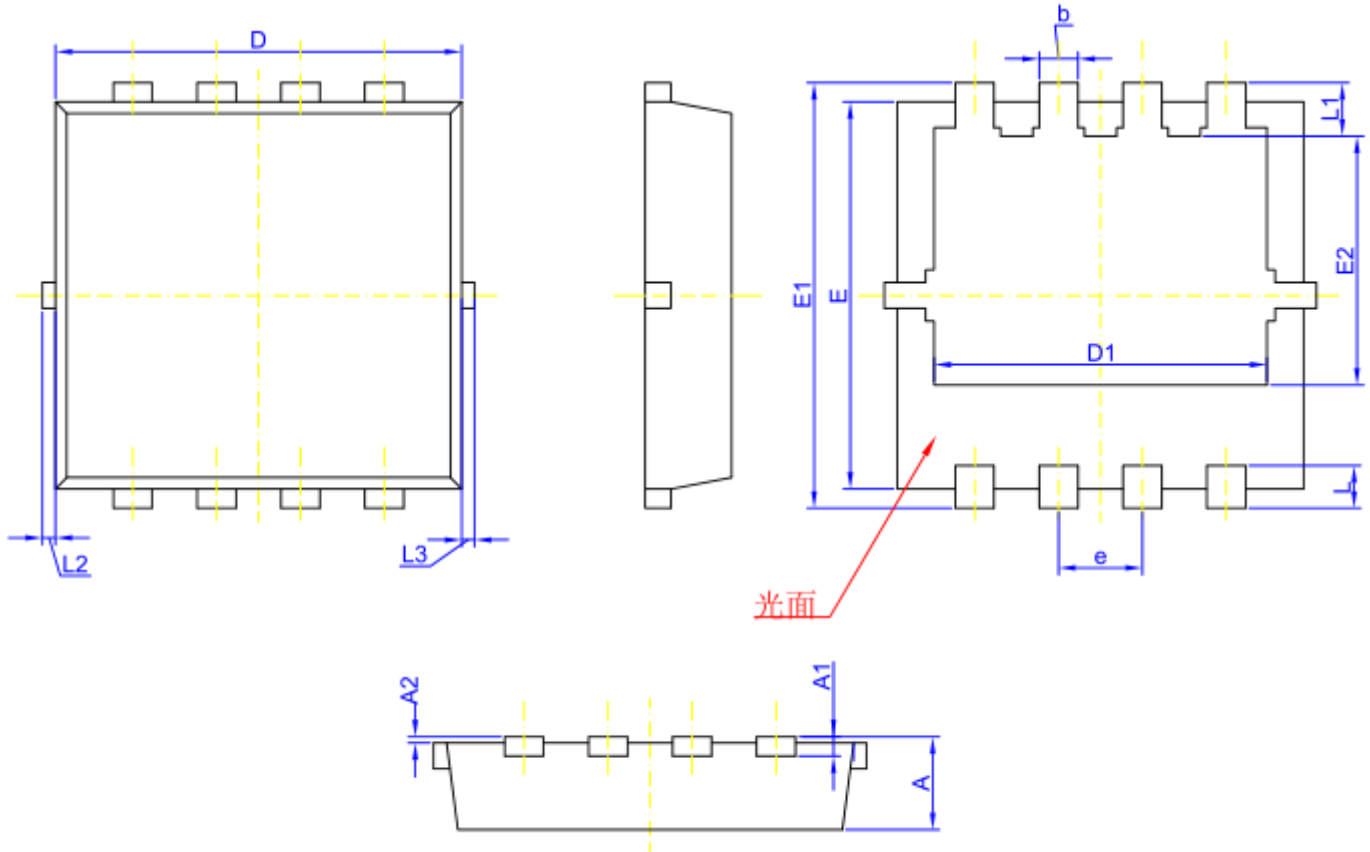

Fig.20 Diode Recovery Test Circuit & Waveforms



8. Package Dimensions

PDFN3.3*3.3 Package



| Symbol | Dimensions In Millimeters | | |
|--------|---------------------------|-------|-------|
| | MIN. | NOM. | MAX. |
| A | 0.700 | 0.800 | 0.900 |
| A1 | 0.100 | 0.150 | 0.200 |
| A2 | - | - | 0.050 |
| D | 3.000 | 3.100 | 3.200 |
| D1 | 2.350 | 2.450 | 2.550 |
| E | 3.000 | 3.100 | 3.200 |
| E1 | 3.200 | 3.400 | 3.600 |
| E2 | 1.635 | 1.735 | 1.835 |
| b | 0.200 | 0.300 | 0.400 |
| e | 0.550 | 0.650 | 0.750 |
| L | 0.250 | 0.450 | 0.650 |
| L1 | 0.345 | 0.545 | 0.745 |
| L2 | 0~0.100 | | |
| L3 | 0~0.100 | | |

9. Record of Document amendment

产品名称: LN065N060Q-L
版权说明: 雷诺电子(宁波)有限公司
联系电话: 4008887385

文档类型: 产品手册
公司主页: www.leinuosemi.com

版本: 01
修改记录:
1.初版发行