

## 120V N-Channel Enhancement Mode MOSFET

### 1. Product Information

#### 1.1 Features

- ◇ Advanced SGT cell design
- ◇ Low Gate Charge
- ◇ Low On-Resistance
- ◇ RoHS and Halogen-Free Compliant
- ◇ 100%  $\Delta V_{DS}$  & UIS & Rg Tested

#### 1.2 Applications

- ◇ DC-DC Converter
- ◇ Drones
- ◇ Motor drivers
- ◇ Light electric vehicles

#### 1.3 Quick reference

- ◇  $BV \cong 120\text{ V}$
- ◇  $P_{\text{tot}} \cong 483\text{ W}$
- ◇  $I_D \cong 383\text{ A}$
- ◇  $R_{DS(ON)} \cong 2.0\text{ m}\Omega @ V_{GS} = 10\text{ V}$
- ◇  $R_{DS(ON)} \cong 2.8\text{ m}\Omega @ V_{GS} = 6\text{ V}$



### 2. Pin Description

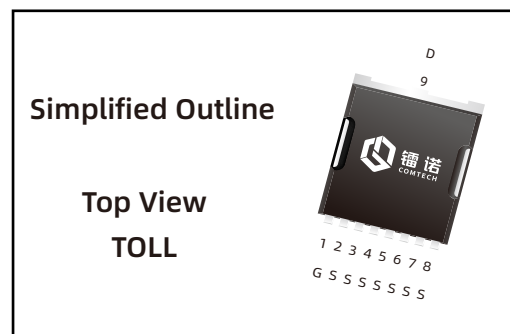
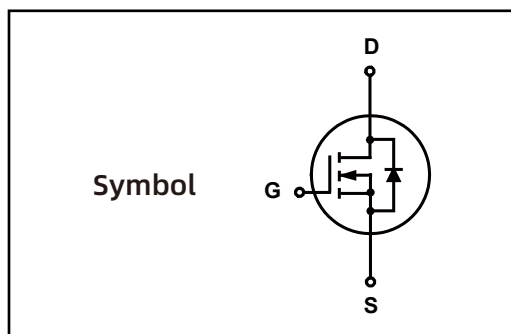

### 3.Limiting Values

Symbol	Parameter	Conditions	Min	Max	Unit	Note
$V_{DS}$	Drain-Source Voltage	$T_C = 25\text{ }^\circ\text{C}$	-	120	V	-
$V_{GS}$	Gate-Source Voltage	$T_C = 25\text{ }^\circ\text{C}$	-	$\pm 20$	V	-
$I_D^*$	Drain Current ( DC )	$T_C = 25\text{ }^\circ\text{C}, V_{GS} = 10\text{ V}$	-	383	A	Fig.2
		$T_C = 100\text{ }^\circ\text{C}, V_{GS} = 10\text{ V}$	-	271	A	
$I_{DM}^{**},^{***}$	Drain Current ( Pulsed )	$T_C = 25\text{ }^\circ\text{C}, V_{GS} = 10\text{ V}$	-	585	A	-
$P_{tot}$	Drain power dissipation	$T_C = 25\text{ }^\circ\text{C}$	-	483	W	Fig.1
		$T_C = 100\text{ }^\circ\text{C}$	-	241	W	
$T_{stg}$	Storage Temperature		-55	175	$^\circ\text{C}$	-
$T_J$	Junction Temperature		-	175	$^\circ\text{C}$	-
$I_S$	Continuous-Source Current	$T_C = 25\text{ }^\circ\text{C}$	-	383	A	-
$E_{AS}^*$	Single Pulsed Avalanche Energy	$V_{DD} = 120\text{ V}, L = 0.1\text{ mH}$	-	1950	mJ	Fig.19

### 4.Thermal Characteristics

$R_{\theta JA}^*$	Thermal Resistance- Junction to Ambient	-	16	$^\circ\text{C}/\text{W}$	Fig.16
$R_{\theta JC}^*$	Thermal Resistance- Junction to Case	-	0.31		

Notes :

- \* Surface Mounted on 1 in<sup>2</sup> pad area,  $t \leq 10\text{ sec}$
- \*\* Pulse width  $\leq 300\text{ }\mu\text{s}$ , duty cycle  $\leq 2\%$
- \*\*\* limited by bonding wire

### 5.Marking Information

Product Name	Package	Reel size	Tape width	Quantity	Note
LN018N120T	TOLL	330mm	24mm	2000	

Note: COMTECH defines " Green " as lead-free ( RoHS compliant ) and halogen free ( Br or Cl does not exceed 900 ppm by weight in homogeneous material and total of Br and Cl does not exceed 1500 ppm by weight; Follow IEC 61249-2-21 and IPC / JEDEC J-STD-020C )

## 6. Electrical Characteristics ( $T_A=25^\circ$ Unless Otherwise Noted )

Symbol	Parameter	Conditions	Min	Typ	Max	Unit	Note
<b>Static Characteristics</b>							
$BV_{DSS}$	Drain-Source Breakdown Voltage	$V_{GS} = 0\text{ V}, I_{DS} = 250\ \mu\text{A}$	120	-	-	V	
$V_{GS(th)}$	Gate Threshold Voltage	$V_{DS} = V_{GS}, I_{DS} = 250\ \mu\text{A}$	2	-	4	V	
$I_{DSS}$	Drain Leakage Current	$V_{DS} = 120\text{ V}, V_{GS} = 0\text{ V}$	-	-	1	$\mu\text{A}$	
$I_{GSS}$	Gate Leakage Current	$V_{GS} = \pm 20\text{ V}, V_{DS} = 0\text{ V}$	-	-	$\pm 100$	nA	
$R_{DS(on)}^a$	On-State Resistance	$V_{GS} = 10\text{ V}, I_{DS} = 30\text{ A}$	-	1.8	2.0	m $\Omega$	Fig.8
		$V_{GS} = 6\text{ V}, I_{DS} = 20\text{ A}$	-	2.4	2.8		
<b>Diode Characteristics</b>							
$V_{SD}^a$	Diode Forward Voltage	$I_{SD} = 30\text{ A}, V_{GS} = 0\text{ V}$	-	-	1.3	V	Fig.7
$t_{rr}$	Reverse Recovery Time	$I_{DS} = 30\text{ A}, V_{GS} = 0\text{ V}$	-	72	-	nS	Fig.20
$Q_{rr}$	Reverse Recovery Charge	$di_{SD}/dt = 100\text{ A}/\mu\text{s}$	-	1137	-	nC	
<b>Dynamic Characteristics<sup>b</sup></b>							
$C_{iss}$	Input Capacitance	$V_{GS} = 0\text{ V}, V_{DS} = 60\text{ V}$ Frequency = 1 MHz	-	13523	-	pF	Fig.10
$C_{oss}$	Output Capacitance		-	1869	-		
$C_{riss}$	Reverse Transfer Capacitance		-	72	-		
$R_G$	Gate Resistance	F = 1 MHz	-	1.4	-	$\Omega$	
$t_d(on)$	Turn-on Delay Time	$V_{DS} = 60\text{ V}, V_{GS} = 10\text{ V},$ $R_G = 2.7\ \Omega, R_L = 20\ \mu\text{H},$ $I_{DS} = 30\text{ A}$	-	48	-	nS	Fig.18
$t_r$	Turn-on Rise Time		-	85	-		
$t_d(off)$	Turn-off Delay Time		-	82	-		
$t_f$	Turn-off Fall Time		-	39	-		
$dv/dt$	Peak Diode Recovery		-	0.565	-		
$di/dt$	Peak Diode Recovery	-	556	-	A/ $\mu\text{s}$		
<b>Gate Charge Characteristics<sup>b</sup></b>							
$Q_g$	Total Gate Charge	$V_{DS} = 60\text{ V}, V_{GS} = 10\text{ V},$ $I_{DS} = 30\text{ A}$	-	158	-	nC	Fig.9
$Q_{gs}$	Gate-Source Charge		-	48	-		
$Q_{gd}$	Gate-Drain Charge		-	38	-		
$V_{plateau}$	Gate plateau voltage		-	4.6	-		

Notes :

a : Pulse test ; pulse width  $\leq 300\ \mu\text{s}$ , duty cycle  $\leq 2\%$ 

b : Guaranteed by design, not subject to production testing

## 7. Typical Characteristics

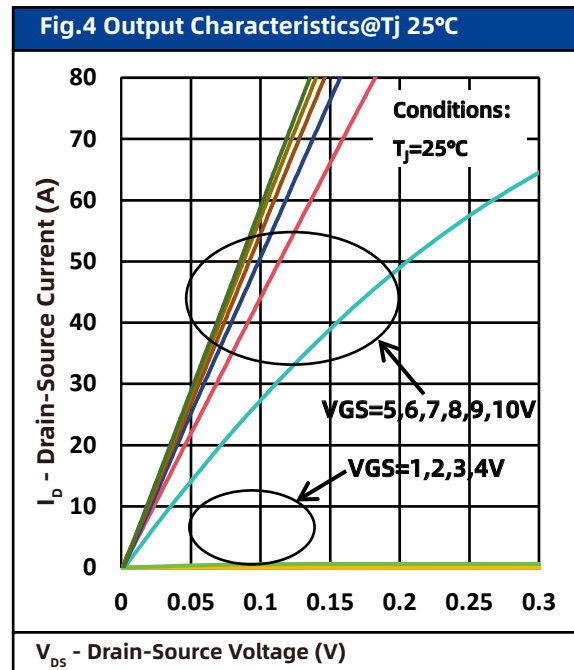
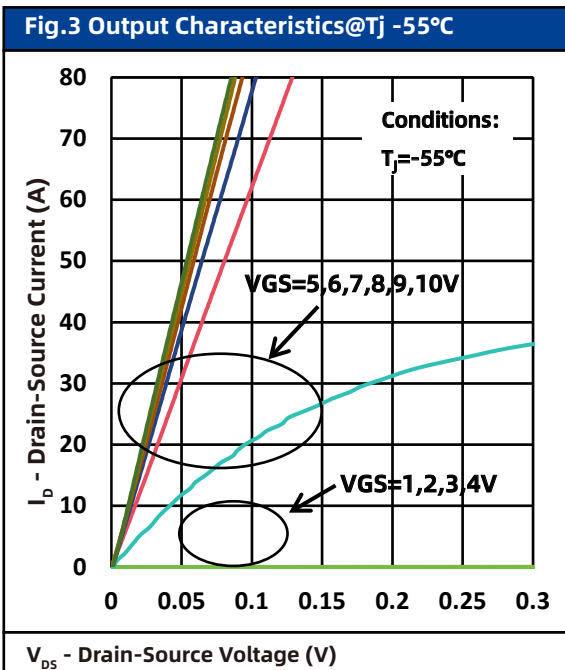
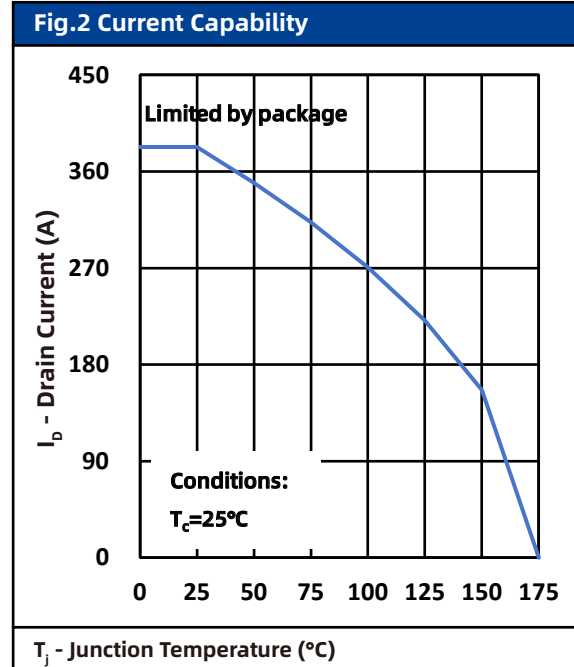
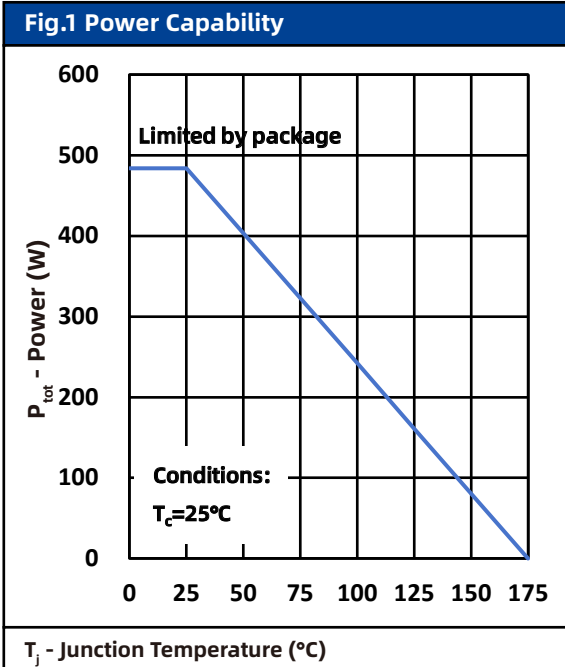

## 7. Typical Characteristics

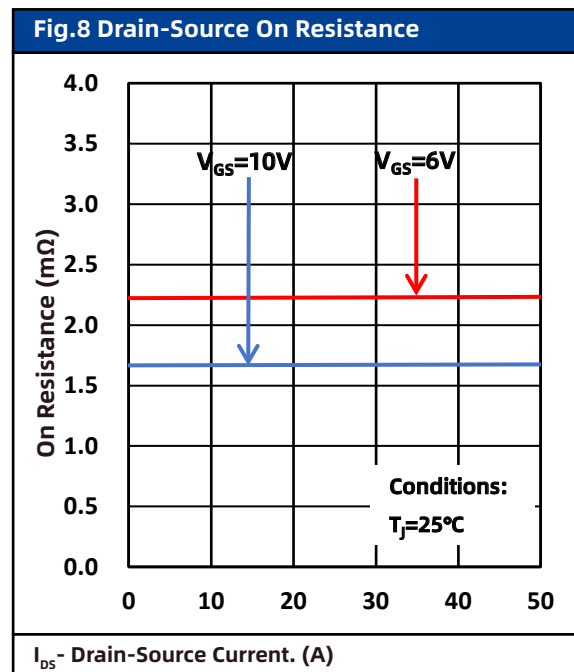
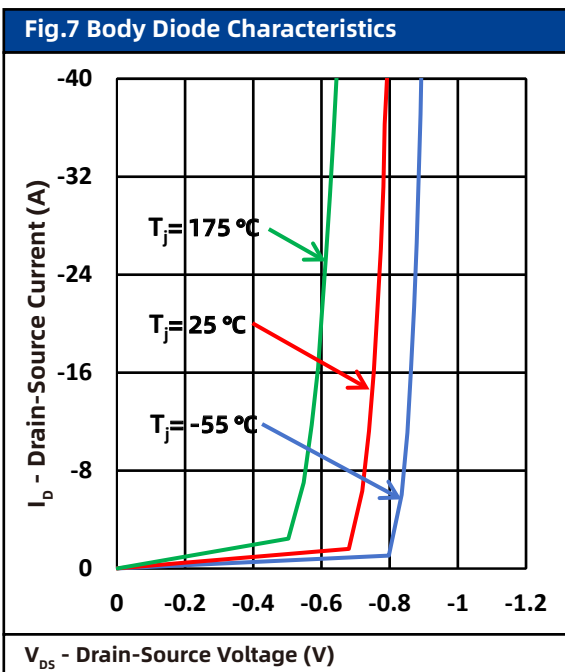
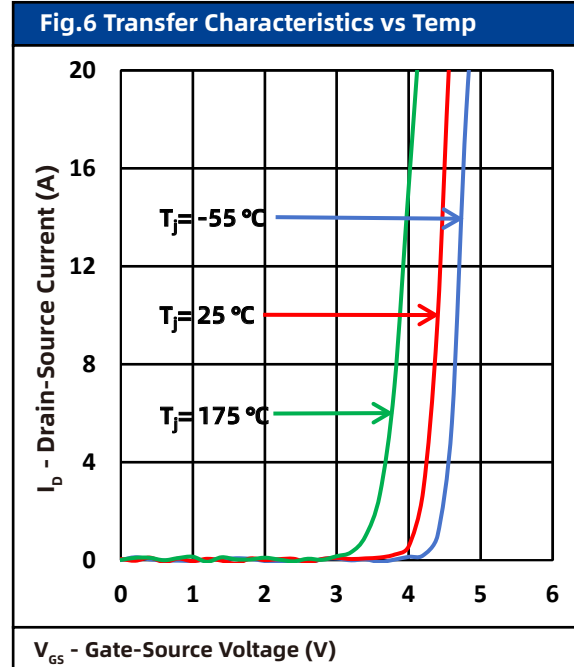
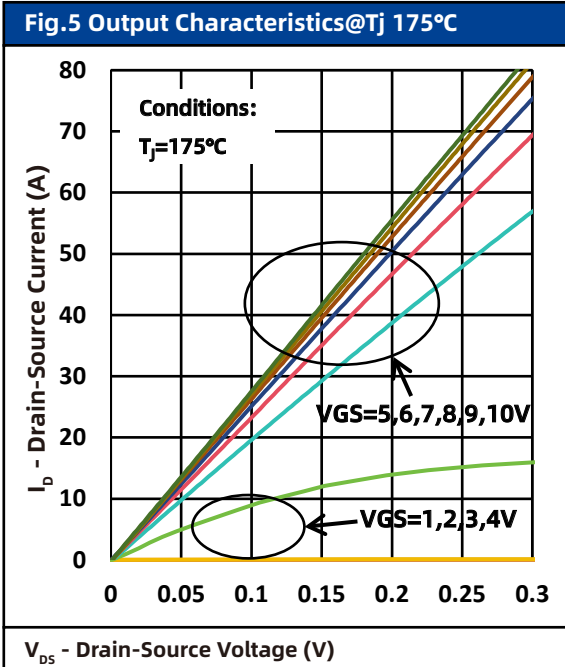

## 7. Typical Characteristics

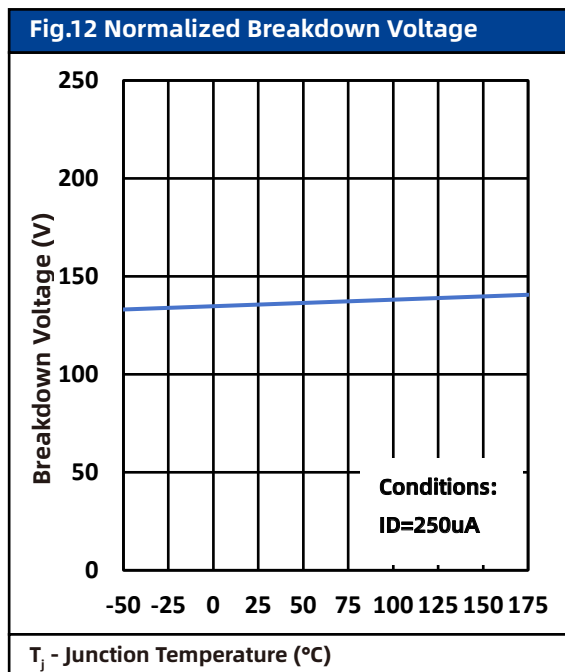
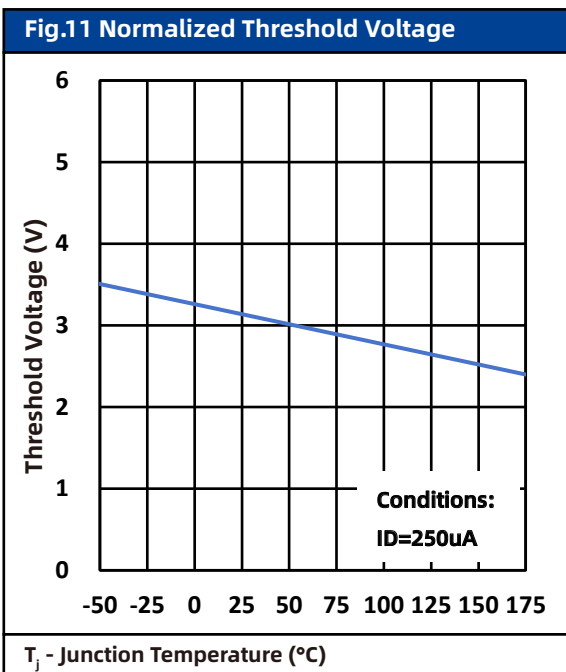
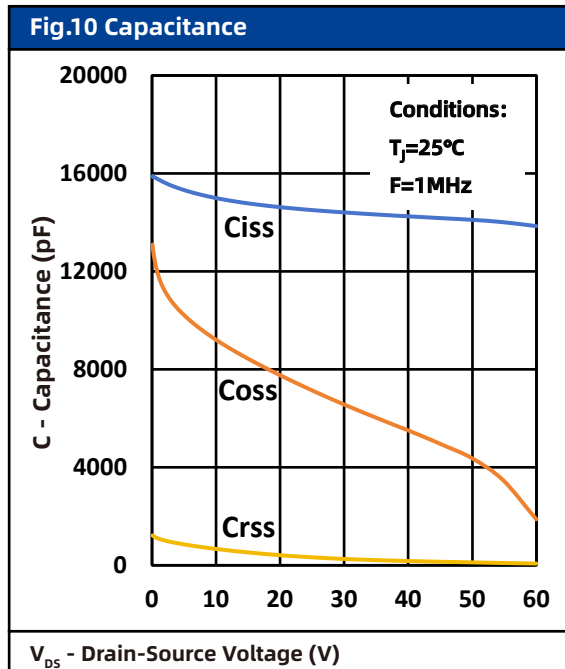
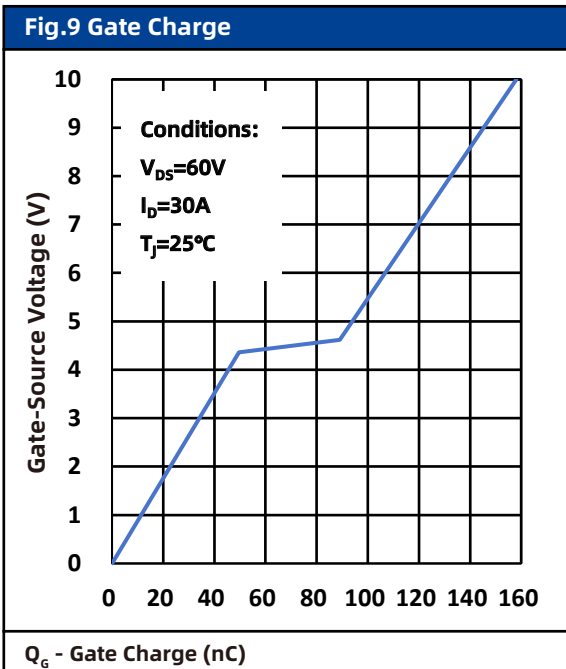

## 7. Typical Characteristics

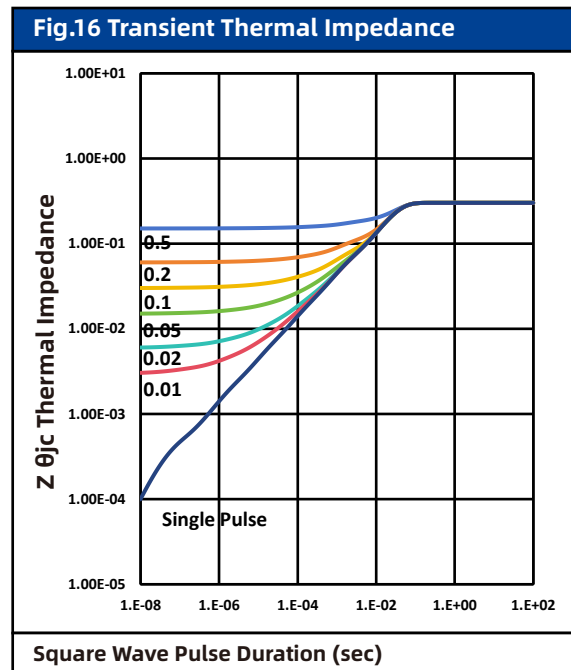
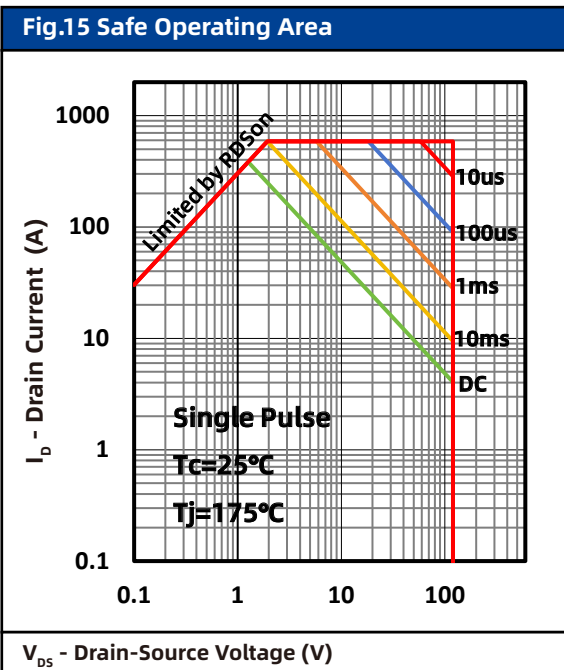
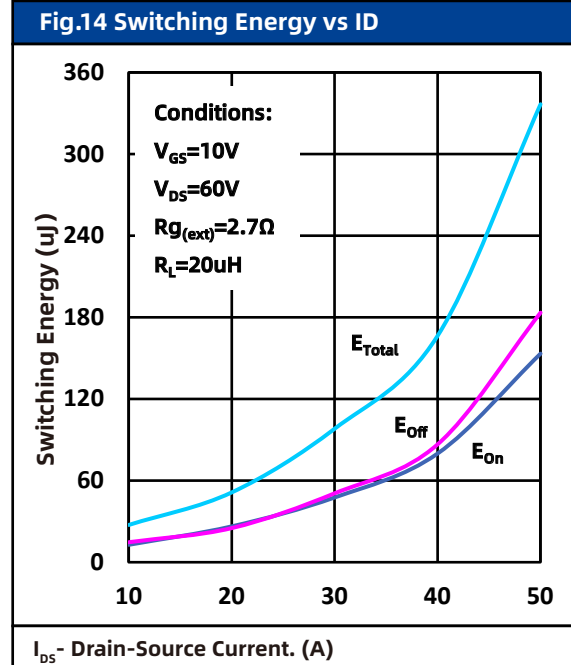
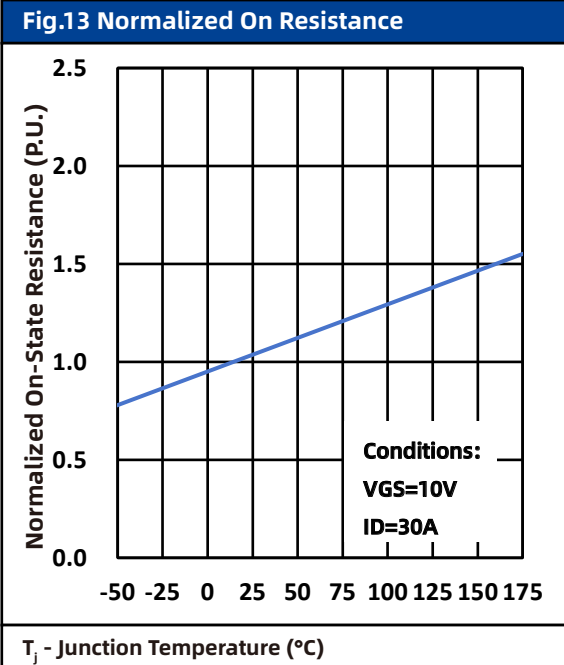

## 7. Typical Characteristics

Fig.17 Gate Charge Test Circuit & Waveform

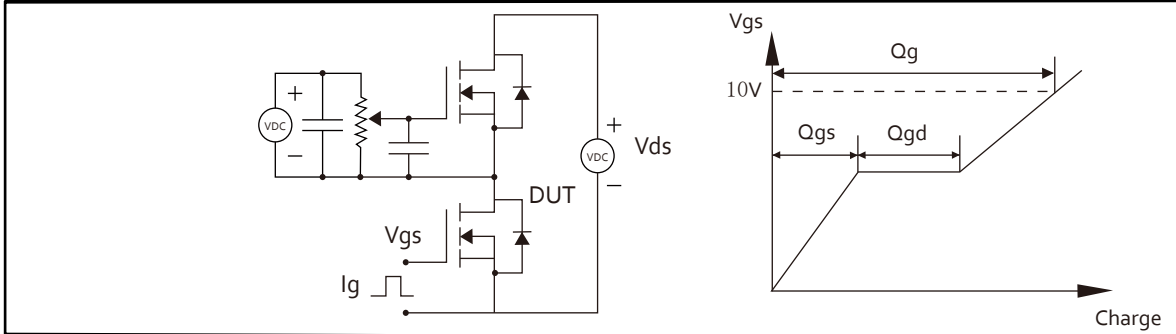

Fig.18 Resistive Switching Test Circuit & Waveforms

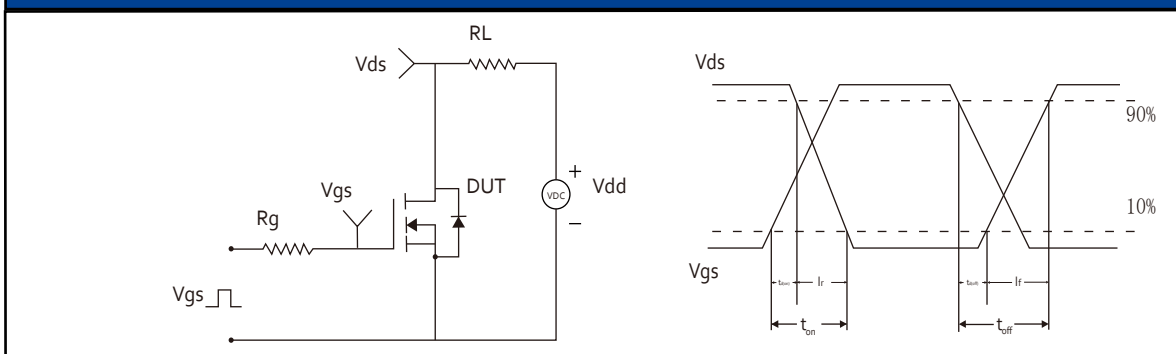

Fig.19 Unclamped Inductive Switching (UIS) Test Circuit & Waveforms

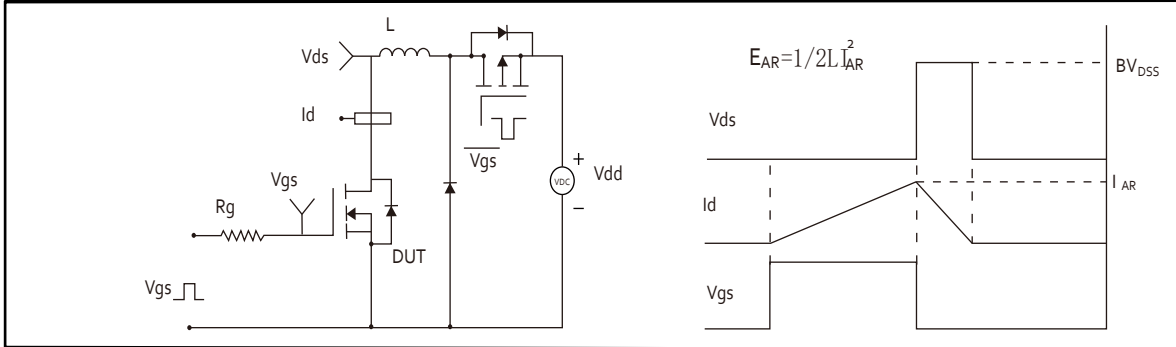
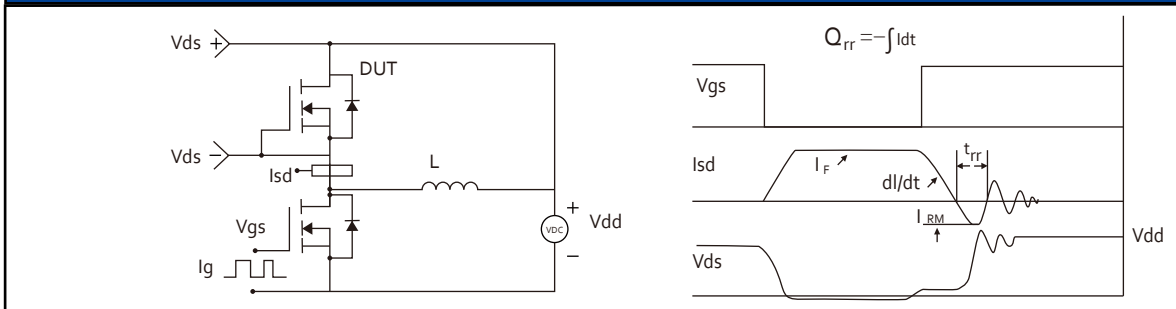
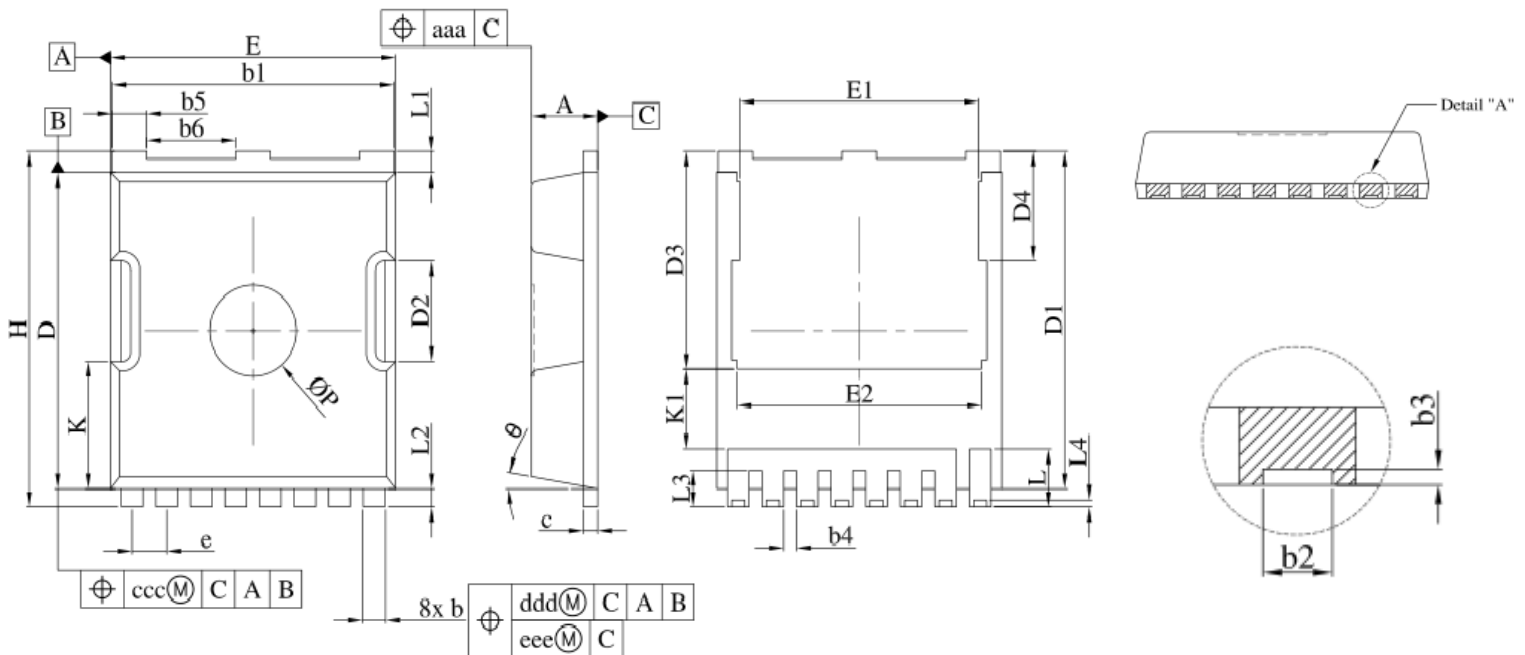

Fig.20 Diode Recovery Test Circuit & Waveforms



## 8. Package Dimensions

### TOLL Package



Symbol	Dimensions In Millimeters		
	MIN.	NOM.	MAX.
A	2.20	2.30	2.40
b	0.70	0.80	0.90
b1	9.70	9.80	9.90
b2	0.36	0.45	0.55
b3	0.05	0.10	0.35
b4	0.30	0.40	0.50
b5	1.10	1.20	1.30
b6	3.00	3.10	3.20
c	0.40	0.50	0.60
D	10.28	10.38	10.55
D1	10.98	11.08	11.18
D2	3.20	3.30	3.40
D3	7.00	7.15	7.30
D4	3.44	3.59	3.74
e	1.10	1.20	1.30
E	9.80	9.90	10.00
E1	8.20	8.30	8.40
E2	8.35	8.50	8.65
H	11.50	11.68	11.85
K	4.08	4.18	4.28
K1	2.45	-	-
L	1.60	1.90	2.10
L1	0.50	0.70	0.90
L2	0.50	0.60	0.70
L3	1.00	1.20	1.30
L4	0.13	0.23	0.33
P	2.85	3.00	3.15
$\theta$		10°REF.	
aaa		0.20	
ccc		0.20	
ddd		0.25	
eee		0.20	

## 9. Record of Document amendment

产品名称：LN018N120T  
版权说明：镭诺电子（宁波）有限公司  
联系电话：4008887385

文档类型：产品手册  
公司主页：[www.leinuosemi.com](http://www.leinuosemi.com)

版本：01  
修改记录：  
1.初版发行